

Llámenos: +503 24491713/ +503 7869 2201
Escríbanos: ventas@sautec.net



Neumática



www.sautec.net

NEUMÁTICA

Unidades de mantenimiento

| | |
|-------------------------------------|-----|
| F.R.L. (2 cuerpos) | 137 |
| Filtro + Regulador | 137 |
| Lubricadores | 137 |
| Bloques de unión (bracket) | 137 |
| Reguladores de presión | 138 |
| Reguladores de presión de precisión | 138 |
| Manómetros | 138 |
| Lubricante especial | 138 |
| Trampas de condensados | 138 |

Válvulas

| | |
|---|-----|
| Plásticas 2/2 NC | 139 |
| Propósito general | 139 |
| Para vapor | 139 |
| Asiento inclinado 2/2 NC | 140 |
| Solenoides 2/2 NC | 140 |
| Solenoides 3/2 NC | 140 |
| Solenoides 5/2 NC | 140 |
| Solenoides 5/2 serie MVSC 220 (Alto caudal) | 140 |
| Solenoides 5/2 serie MVSC 260 (Alto caudal) | 141 |
| Solenoides 5/2 serie MVSC 300 (Alto caudal) | 141 |
| Solenoides 5/2 | 141 |
| Solenoides 5/3 | 141 |
| Direccionales neumáticas 3/2 NC | 141 |
| Direccionales neumáticas 5/2 | 142 |
| Direccionales neumáticas 5/3 | 142 |
| Manifold para válvulas 3/2 | 142 |
| Manifold para válvulas 5/2 | 142 |
| Accesorios V. Solenoides | 142 |

Válvulas manuales

| | |
|--------------------------------|-----|
| Rotativas 4/2, serie 4HV | 143 |
| Rotativas 4/2, serie HV | 143 |
| Botón 3/2 NC, serie 4R | 143 |
| Palanca 5/2, serie 4H | 143 |
| Pedal 5/2, serie FOV | 143 |
| Pedal 5/2, serie ST | 143 |
| Corredera 3/2 | 144 |
| Anti-retorno serie CV | 144 |
| Anti-retorno serie LCV | 144 |
| Control de flujo serie AS | 144 |
| Control de flujo serie RE | 144 |
| Control de flujo serie ASC | 144 |
| Control de flujo serie ASC | 145 |
| Escape rápido series SEU y BQE | 145 |
| Escape rápido series QE | 145 |
| Escape rápido series KV | 145 |
| Codillo serie HL | 145 |

| | |
|--------------------------|-----|
| Mecánicas 3/2, serie MOV | 146 |
| Mecánicas 3/2, serie JM | 146 |
| Mecánicas 5/2, serie VM | 146 |

Vacío

| | |
|---------------------------------------|-----|
| Generadores serie SCV | 147 |
| Generadores serie SCV con silenciador | 147 |
| Generadores serie ZH | 147 |

Actuadores neumáticos

| | |
|--|-----|
| Cilindros Mickey Mouse serie SC, doble efecto | 149 |
| Cilindros Mickey Mouse serie SU, doble efecto | 149 |
| Accesorios serie SC, SU | 149 |
| Cilindros ISO6431 serie TGD o DNC, doble efecto | 150 |
| Accesorios para actuadores neumáticos ISO6431 | 150 |
| Kit para cilindros ISO6431 serie TGD o DNC, doble efecto | 150 |
| Cilindros redondos en aluminio serie MAL, doble efecto | 157 |
| Cilindros redondos en acero inox. Serie MA, doble efecto | 151 |
| Accesorios para cilindros MAL/MA | 151 |
| Kit para cilindros redondos serie MAL, doble efecto | 151 |
| Cilindros multimontaje serie MD, doble efecto | 152 |
| Cilindros dobles (twin) serie TN, doble efecto | 152 |
| Cilindros compactos serie SDA, doble efecto | 152 |
| Mini cilindros serie CJPB, simple efecto | 152 |
| Amortiguadores de choque ajustables | 153 |
| Sensores magnéticos | 155 |

Mangueras

| | |
|--|-----|
| Mangueras plásticas | 157 |
| Mangueras en espiral de poliuretano (PU) | 157 |

Accesorios para mangueras

| | |
|--------------------------|-----|
| Pistolas para aire | 157 |
| Cortadores para manguera | 158 |

Racores

| | |
|--|-----|
| Acoples rápidos | 158 |
| Adaptadores para manguera | 159 |
| Racores instantáneos | 160 |
| Racores instantáneos serie métrica | 161 |
| Racores instantáneos serie pulgadas roscados | 161 |
| Racores instantáneos serie pulgadas | 162 |
| Silenciadores | 162 |

Herramienta neumática

| | |
|----------------|-----|
| Multifuncional | 162 |
|----------------|-----|

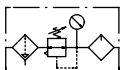
UNIDADES DE MANTENIMIENTO
F.R.L (2 Cuerpos)
EBCHQ SNS

85003|85005



85007



85009



85008



85012|85014



85016|85017

| REF | PUERTOS | RANGO FLUJO (l/min) | REFERENCIAS DE PARTES | | | | DRENAJE | MARCA |
|-------|----------|---------------------|-----------------------|------------|---------|-----------|----------|-------|
| | | | Filtro/Reg. | Lubricador | Bracket | Manómetro | | |
| 85003 | 1/4" NPT | 500 | 85040 | 85035 | 85060 | 85055 | Manual | EBCHQ |
| 85005 | | | | | | | Semiauto | SNS |
| 85007 | | | | | | | Auto | EBCHQ |
| 85009 | | | | | | | Auto | SNS |
| 85008 | | 1700 | N/A | N/A | N/A | 85055 | Auto | EBCHQ |
| 85012 | | | | | | | Semiauto | SNS |
| 85014 | | | | | | | Semiauto | SNS |
| 85016 | | | | | | | Auto | EBCHQ |
| 85017 | 3/4" NPT | 3000 | 85046 | 85048 | 85063 | 85057 | Auto | EBCHQ |

Unidad filtrante de 40µ, Máxima presión: 145 PSI

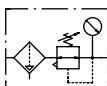
UNIDADES DE MANTENIMIENTO
FILTRO + REGULADOR
EBCHQ

85040



85044 a 85046

| REF | PUERTOS | RANGO FLUJO (l/min) | REFERENCIAS DE PARTES | | | | F.R.L. |
|-------|----------|---------------------|-----------------------|------------|---------|-----------|------------|
| | | | Filtro/Reg. | Lubricador | Bracket | Manómetro | |
| 85040 | 1/4" NPT | 550 | 85040 | N/A | N/A | 85055 | 85003 a 07 |
| 85044 | 3/8" NPT | 2000 | 85044 | | | | 85012 y 14 |
| 85045 | 1/2" NPT | 4000 | 85045 | | | 85057 | 85016 |
| 85046 | 3/4" NPT | | 85046 | | | | 85017 |

Rango de regulación: 7~145PSI - Manómetro incluido

UNIDADES DE MANTENIMIENTO
LUBRICADORES
EBCHQ

85035 a 85048

| REF | PUERTOS | RANGO FLUJO (l/min) | REFERENCIAS DE PARTES | | | | F.R.L. |
|-------|----------|---------------------|-----------------------|------------|---------|-----------|------------|
| | | | Filtro/Reg. | Lubricador | Bracket | Manómetro | |
| 85035 | 1/4" NPT | 800 | N/A | 85035 | N/A | N/A | 85003 a 07 |
| 85047 | 3/8" NPT | 1700 | | 85047 | | | 85012 y 14 |
| 85037 | 1/2" NPT | 5000 | | 85037 | | | 85016 |
| 85048 | 3/4" NPT | 6300 | | 85048 | | | 85017 |

UNIDADES DE MANTENIMIENTO
BLOQUES DE UNIÓN (BRACKET)
EBCHQ

85060

85061 | 85062

85063

| REF | PUERTOS | RANGO FLUJO (l/min) | REFERENCIAS DE PARTES | | | | F.R.L. |
|-------|---------|---------------------|-----------------------|------------|---------|-----------|------------|
| | | | Filtro/Reg. | Lubricador | Bracket | Manómetro | |
| 85060 | N/A | N/A | 85040 | 85035 | N/A | 85055 | 85003 a 07 |
| 85061 | | | 85044 | 85047 | | | 85012 y 14 |
| 85062 | | | 85045 | 85037 | | 85057 | 85016 |
| 85063 | | | 85046 | 85048 | | | 85017 |

Incluyen O'rings (2 unidades por pieza)

UNIDADES DE MANTENIMIENTO
REGULADORES DE PRESIÓN
EBCHQ

| REF | PUERTOS | RANGO FLUJO (l/min) | RANGO PRESIÓN (AJUSTABLE) | | MANÓMETRO | |
|---------|----------|---------------------|---------------------------|-----------|------------|----------|
| | | | psi | bar | Referencia | Conexión |
| 85031-4 | M5 | 100 | 7 ~ 100 | 0.5 ~ 0.7 | | G1/16" |
| 85031 | 1/8" NPT | 550 | 7 ~ 145 | 0.5 ~ 10 | 85055 | G1/8" |
| 85030 | 1/4" NPT | | | | | |
| 85026 | 3/8" NPT | 2500 | | | | |
| 85028 | 1/2" NPT | 6000 | | | 85057 | G1/4" |
| 85024 | 3/4" NPT | | | | | |

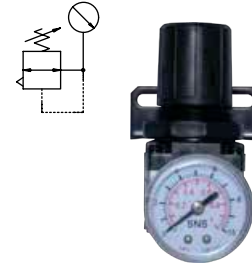
UNIDADES DE MANTENIMIENTO
REGULADORES DE PRESIÓN DE PRECISIÓN
EBCHQ

| REF | PUERTOS | CONSUMO AIRE MAX. (L/min) | RANGO PRESIÓN (AJUSTABLE) | | MANÓMETRO | |
|---------|----------|---------------------------|---------------------------|-------|------------|----------|
| | | | psi | bar | Referencia | Conexión |
| 85019 | 1/8" NPT | 3.5 | 0.7 ~ 30 | 0 ~ 2 | N/A | G1/8" |
| 85019-1 | | | 1.4 ~ 60 | 0 ~ 4 | | |
| 85020 | 1/4" NPT | 3.1 | 0.7 ~ 30 | 0 ~ 2 | | |
| 85020-1 | | | 1.4 ~ 60 | 0 ~ 4 | | |
| 85021 | 3/8" NPT | 9.5 | 0.7 ~ 30 | 0 ~ 2 | | |
| 85021-1 | | | 1.4 ~ 60 | 0 ~ 4 | | |

Mínima presión aplicable: Presión requerida + 7.2psi, precisión ±0.5%, sensibilidad ≤0.2%

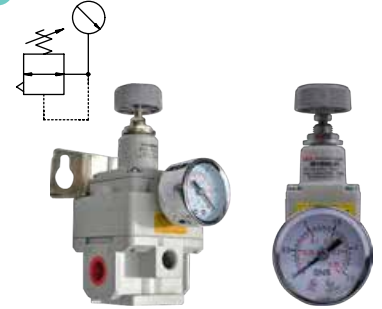
UNIDADES DE MANTENIMIENTO
MANÓMETROS
EBCHQ

| REF | PUERTOS | DIÁMETRO CARÁTULA | RANGO PRESIÓN | | CONEXIÓN | INDICACIÓN |
|-------|----------|-------------------|---------------|--------|-----------|------------|
| | | | psi | bar | | |
| 85055 | 1/8" NPT | 40mm | 0 ~ 150 | 0 ~ 10 | Posterior | psi y bar |
| 85057 | 1/4" NPT | 50mm | | | | |

UNIDADES DE MANTENIMIENTO
LUBRICANTE ESPECIAL
SNS

| REF | RANGO VISCOSIDAD | TIPO LUBRICANTE | RECIPIENTE | ENVASE |
|-------|------------------|------------------------|------------|----------|
| 84990 | 32 mm/s | Turbine No. 1 Estandar | 1 litro | Metálico |

Especial para unidades de mantenimiento y sistemas neumáticos

UNIDADES DE MANTENIMIENTO
TRAMPAS DE CONDENSADOS

| REF | PUERTOS | | RANGO PRESIÓN | | Rango Flujo (l/min) | TIPO DRENAJE |
|-------|----------|--------------|---------------|--------------------|---------------------|--------------|
| | CONEXIÓN | DRENAJE | psi | kg/cm ² | | |
| 85050 | RC 1/2" | Manguera 6mm | 0 ~ 142 | 0 ~ 10 | 3000 | Automático |
| 85052 | | RC 3/8" | | | 2500 | |

Uso en líneas de aire comprimido



85050

85052

NEUMÁTICA

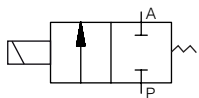

VÁLVULAS

PLÁSTICAS 2/2 NC

SERIE TF

EBCHQ

| REF | PUERTO | DIÁMETRO NOMINAL | CV | PRESIÓN DE TRABAJO | | VOLTAJE | FLUIDO | OPERACIÓN |
|-------|----------|------------------|------|--------------------|--------------------|---------|-------------------------|----------------|
| | | | | psi | kg/cm ² | | | |
| 91220 | 1/8" NPT | 2.5 mm | 0.23 | 0 ~ 100 | 0 ~ 7.14 | 24V DC | Aire, Agua, Aceite, Gas | Acción directa |
| 91223 | | | | | | 110V AC | | |
| 91226 | | | | | | 220V AC | | |
| 91230 | 1/4" NPT | | | | | 24V DC | | |
| 91233 | | | | | | 110V AC | | |
| 91236 | | | | | | 220V AC | | |

Material del cuerpo: Plástico de ingeniería, material del sello: NBR

VÁLVULAS

PROPOSITO GENERAL

SERIE TE

EBCHQ



| REF | PUERTO | DIÁMETRO NOMINAL | CV | PRESIÓN DE TRABAJO | | VOLTAJE | FLUIDO | OPERACIÓN |
|-------|----------|------------------|----|--------------------|--------------------|---------|--------------------|---------------|
| | | | | psi | kg/cm ² | | | |
| 91118 | 1/2" NPT | 13 mm | | 14.5 ~ 145 | 1.02 ~ 10.2 | 110V AC | Aire, Agua, Aceite | Servo operada |
| 91120 | | | | | | 220V AC | | |
| 91121 | 3/4" NPT | 20 mm | | | | 110V AC | | |
| 91122 | | | | | | 220V AC | | |
| 91124 | 1" NPT | 25 mm | | | | 110V AC | | |
| 91126 | | | | | | 220V AC | | |

Protección IP65

SERIE TD



91107 | 91109

91111 | 91117

| REF | PUERTO | DIÁMETRO NOMINAL | CV | PRESIÓN DE TRABAJO | | VOLTAJE | FLUIDO | OPERACIÓN |
|-------|----------|------------------|----|--------------------|--------------------|---------|--------------------|----------------|
| | | | | psi | kg/cm ² | | | |
| 91107 | 1/8" NPT | 2 mm | | 0 ~ 145 | 0 ~ 10.2 | 110V AC | Aire, Agua, Aceite | Acción directa |
| 91109 | | | | | | 220V AC | | |
| 91111 | 1/4" NPT | | | | | 110V AC | | |
| 91117 | | | | | | 220V AC | | |

Solenoides con LED incorporado. Protección IP65

SERIE TUW



| REF | PUERTO | DIÁMETRO NOMINAL | CV | PRESIÓN DE TRABAJO | | VOLTAJE | FLUIDO | OPERACIÓN |
|-------|----------|------------------|----|--------------------|--------------------|---------|--------------------|---------------|
| | | | | psi | kg/cm ² | | | |
| 91138 | 3/8" NPT | 16 mm | | 0 ~ 116 | 0 ~ 8.16 | 110V AC | Aire, Agua, Aceite | Servo operada |
| 91140 | | | | | | 220V AC | | |
| 91142 | 1/2" NPT | 20 mm | | | | 110V AC | | |
| 91144 | | | | | | 220V AC | | |
| 91146 | 3/4" NPT | | | | | 110V AC | | |
| 91148 | | | | | | 220V AC | | |
| 91150 | 1" NPT | 25 mm | | | | 110V AC | | |
| 91152 | | | | | | 220V AC | | |

Protección IP65

VÁLVULAS

PARA VAPOR

SERIE T4S

EBCHQ



| REF | PUERTO | DIÁMETRO NOMINAL | CV | PRESIÓN DE TRABAJO | | VOLTAJE | FLUIDO | OPERACIÓN |
|-------|----------|------------------|----|--------------------|--------------------|---------|---------------|------------------|
| | | | | psi | kg/cm ² | | | |
| 91172 | 1/2" NPT | 17 mm | | 7 ~ 217 | 0.5 ~ 15 | 110V AC | Vapor de agua | Embolo (Plunger) |
| 91174 | | | | | | 220V AC | | |
| 91176 | 3/4" NPT | | | | | 110V AC | | |
| 91178 | | | | | | 220V AC | | |
| Nueva | 1" NPT | 20 mm | | | | 110V AC | | |
| Nueva | | | | | | 220V AC | | |

Temperatura Max. 185°C, protección IP65

VÁLVULAS

ASIENTO INCLINADO 2/2 NC

| REF | PUERTO | ÁREA EFECTIVA | CV | PRESIÓN CONTROL | DIÁMETRO ACTUADOR | FLUIDO | | PUERTOS ACTUADOR |
|-------|------------|--------------------|------|-----------------|-------------------|-------------|---------------|------------------|
| | | | | | | Presión | Temp. | |
| 91198 | 1/2" NPT | 13 mm ² | 4.9 | 58 ~ 150 psi | 50 mm | 0 ~ 232 psi | -10°C a 180°C | G1/4" |
| 91200 | 3/4" NPT | 20 mm ² | 9.3 | | | | | |
| 91202 | 1" NPT | 25 mm ² | 22.2 | | | | | |
| 91204 | 1 1/4" NPT | 32 mm ² | 32.1 | | | | | |
| Nuevo | 1 1/2" NPT | 40 mm ² | 49 | | | | | |
| Nuevo | 2" NPT | 50 mm ² | 60.7 | | | | | |

Cuerpo de la Válvula en acero inox., sellos en teflón, para aire, agua o aceite

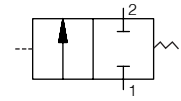

EBCHQ



VÁLVULAS

SOLENOIDES 2/2 NC

SERIE TG

| REF | PUERTO | DIÁMETRO NOMINAL | CV | PRESIÓN DE TRABAJO | | VOLTAJE | REF. SOLENOIDE | OPERACIÓN |
|-------|----------|------------------|------|--------------------|--------------------|----------|----------------|----------------|
| | | | | psi | kg/cm ² | | | |
| 91260 | 1/8" NPT | 1.2mm | 0.23 | 0 ~ 116 | 0 ~ 8.16 | 24V DC | 91391 | Acción directa |
| 91263 | | | | | | 110V AC | 91392 | |
| 91108 | | | | | | 220V AC | 91393 | |
| 91266 | | | | | | 24V DC | 91391 | |
| 91269 | | | | | | 110V AC | 91392 | |
| 91116 | | | | | | 1/4" NPT | 220V AC | |

Solenoides con LED incorporado. Protección IP65

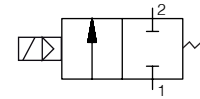

EBCHQ



CE

VÁLVULAS

SOLENOIDES 3/2 NC

| REF | PUERTO | DIÁMETRO NOMINAL | CV | PRESIÓN DE TRABAJO | | VOLTAJE | REF. SOLENOIDE | OPERACIÓN |
|-------|----------|------------------|------|--------------------|--------------------|---------|----------------|------------------------------|
| | | | | psi | kg/cm ² | | | |
| 91280 | 1/8" NPT | 4mm | 0.56 | 21 ~ 116 | 1.5 ~ 8.16 | 24V DC | 91391 | Acción pilotada internamente |
| 91283 | | | | | | 110V AC | 91392 | |
| 91293 | | | | | | 24V DC | 91391 | |
| 91296 | 1/4" NPT | 4.5mm | 0.78 | | | 110V AC | 91392 | |

Solenoides con LED incorporado. Protección IP65

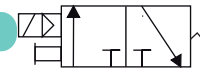

EBCHQ



CE

VÁLVULAS

SOLENOIDES 5/2

| REF | PUERTO | DIÁMETRO NOMINAL | CV | PRESIÓN DE TRABAJO | | VOLTAJE | REF. SOLENOIDE | OPERACIÓN |
|-------|----------|------------------|------|--------------------|--------------------|---------|----------------|------------------------------|
| | | | | psi | kg/cm ² | | | |
| 91319 | 1/8" NPT | 4mm | 0.67 | 21 ~ 116 | 1.5 ~ 8.16 | 24V DC | 91391 | Acción pilotada internamente |
| 91322 | | | | | | 110V AC | 91392 | |
| 91343 | 1/4" NPT | 4.5mm | 0.78 | | | 24V DC | 91391 | |
| 91346 | | | | | | 110V AC | 91392 | |

Solenoides con LED incorporado. Protección IP65

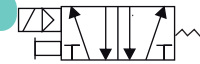

EBCHQ



CE

VÁLVULAS

SOLENOIDES 5/2, SERIE MVSC 220 (ALTO CAUDAL)

| REF | PUERTO | ÁREA EFECTIVA | CV | PRESIÓN CONTROL | | VOLTAJE | REF. SOLENOIDE | OPERACIÓN |
|-------|----------|--------------------|------|-----------------|--------------------|---------|----------------|------------------------------|
| | | | | psi | kg/cm ² | | | |
| 91540 | 1/4" NPT | 14 mm ² | 0.78 | 21 ~ 116 | 1.5 ~ 8.16 | 12V DC | | Acción pilotada internamente |
| 91542 | | | | | | 24V DC | 91391 | |
| 91546 | | | | | | 24V AC | | |
| 91548 | | | | | | 110V AC | 91392 | |
| 91550 | | | | | | 220V AC | 91393 | |

Solenoides con LED incorporado. Protección IP65. Ancho 22mm.

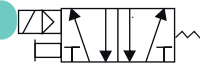

SNS



VÁLVULAS

SOLENOIDES 5/2, SERIE MVSC 260 (ALTO CAUDAL)

SNS

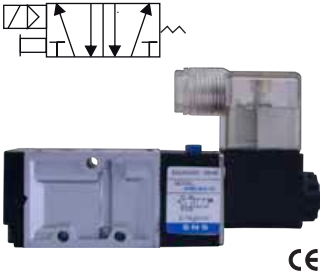

| REF | PUERTO | ÁREA EFECTIVA | CV | PRESIÓN CONTROL | | VOLTAJE | REF. SOLENOIDE | OPERACIÓN |
|-------|----------|--------------------|-----|-----------------|--------------------|---------|----------------|------------------------------|
| | | | | psi | kg/cm ² | | | |
| 91560 | 1/4" NPT | 25 mm ² | 1.4 | 21 ~ 116 | 1.5 ~ 8.16 | 12V DC | | Acción pilotada internamente |
| 91562 | | | | | | 24V DC | | |
| 91565 | | | | | | 24V AC | | |
| 91567 | | | | | | 110V AC | | |
| 91569 | | | | | | 220V AC | | |

Solenoides con LED incorporado. Protección IP65, ancho de 26mm

VÁLVULAS

SOLENOIDES 5/2, SERIE MVSC 300 (ALTO CAUDAL)

SNS

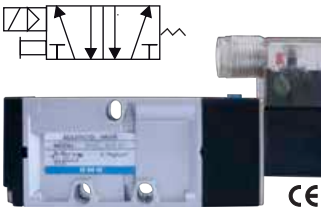

| REF | PUERTO | ÁREA EFECTIVA | CV | PRESIÓN CONTROL | | VOLTAJE | REF. SOLENOIDE | OPERACIÓN |
|-------|----------|--------------------|-----|-----------------|--------------------|---------|----------------|------------------------------|
| | | | | psi | kg/cm ² | | | |
| 91575 | 3/8" NPT | 50 mm ² | 2.8 | 21 ~ 116 | 1.5 ~ 8.16 | 110V AC | 91392 | Acción pilotada internamente |
| 91577 | | | | | | 220V AC | 91393 | |

Solenoides con LED incorporado. Protección IP65, ancho de 300mm

VÁLVULAS

SOLENOIDES 5/2

EBCHQ

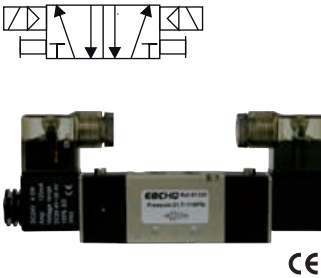

| REF | PUERTO | DIÁMETRO NOMINAL | CV | PRESIÓN DE TRABAJO | | VOLTAJE | REF. SOLENOIDE | OPERACIÓN |
|-------|----------|------------------|------|--------------------|--------------------|---------|----------------|------------------------------|
| | | | | psi | kg/cm ² | | | |
| 91330 | 1/8" NPT | 4mm | 0.67 | 21 ~ 116 | 1.5 ~ 8.16 | 24V DC | 91391 | Acción pilotada internamente |
| 91333 | | | | | | 110V AC | 91392 | |
| 91352 | 1/4" NPT | 4.5mm | 0.78 | | | 24V DC | 91391 | |
| 91355 | | | | | | 110V AC | 91392 | |

Doble solenoide con LED incorporado. Protección IP65

VÁLVULAS

SOLENOIDES 5/3

EBCHQ

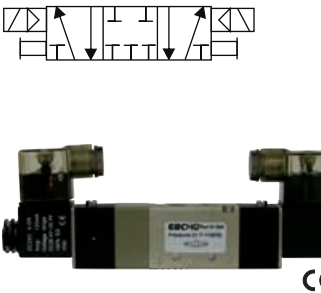

CENTROS ABIERTOS

| REF | PUERTO | DIÁMETRO NOMINAL | CV | PRESIÓN DE TRABAJO | | VOLTAJE | REF. SOLENOIDE | OPERACIÓN |
|-------|----------|------------------|------|--------------------|--------------------|---------|----------------|------------------------------|
| | | | | psi | kg/cm ² | | | |
| 91384 | 1/8" NPT | 3.5 mm | 0.67 | 30 ~ 116 | 2 ~ 8.16 | 24V DC | 91391 | Acción pilotada internamente |
| 91387 | | | | | | 110V AC | 91392 | |

Doble solenoide con LED incorporado. Protección IP65

CENTROS CERRADOS

| REF | PUERTO | DIÁMETRO NOMINAL | CV | PRESIÓN DE TRABAJO | | VOLTAJE | REF. SOLENOIDE | OPERACIÓN |
|-------|----------|------------------|------|--------------------|--------------------|---------|----------------|------------------------------|
| | | | | psi | kg/cm ² | | | |
| 91378 | 1/8" NPT | 3.5 mm | 0.67 | 30 ~ 116 | 2 ~ 8.16 | 24V DC | 91391 | Acción pilotada internamente |
| 91381 | | | | | | 110V AC | 91392 | |

Doble solenoide con LED incorporado. Protección IP65

VÁLVULAS

DIRECCIONALES NEUMÁTICAS 3/2 NC

EBCHQ

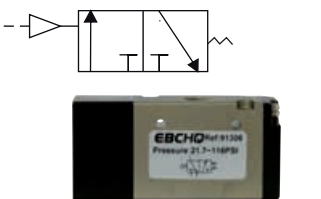

| REF | PUERTO | DIÁMETRO NOMINAL | CV | PRESIÓN DE TRABAJO | | VOLTAJE | REF. SOLENOIDE | OPERACIÓN |
|-------|----------|------------------|------|--------------------|--------------------|---------|----------------|---------------------------------------|
| | | | | psi | kg/cm ² | | | |
| 91306 | 1/8" NPT | 6 mm | 0.56 | 21 ~ 116 | 1.5 ~ 8.16 | N/A | N/A | Sencilla aire con retorno por resorte |
| 91309 | 1/4" NPT | 8 mm | 0.78 | | | | | |

VÁLVULAS

DIRECCIONALES NEUMÁTICAS 5/2

EBCHQ

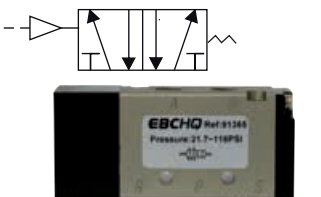

| REF | PUERTO | DIÁMETRO NOMINAL | CV | PRESIÓN DE TRABAJO | | VOLTAJE | REF. SOLENOIDE | OPERACIÓN |
|-------|----------|------------------|------|--------------------|--------------------|---------|----------------|---------------------------------------|
| | | | | psi | kg/cm ² | | | |
| 91365 | 1/8" NPT | 6 mm | 0.67 | 21 ~ 116 | 1.5 ~ 8.16 | N/A | N/A | Sencilla aire con retorno por resorte |

VÁLVULAS
DIRECCIONALES NEUMÁTICAS 5/2

| REF | PUERTO | DIÁMETRO NOMINAL | CV | PRESIÓN DE TRABAJO | | VOLTAJE | REF. SOLENOIDE | OPERACIÓN |
|-------|----------|------------------|------|--------------------|--------------------|---------|----------------|------------------------------------|
| | | | | psi | kg/cm ² | | | |
| 91368 | 1/8" NPT | 6 mm | 0.67 | 21 ~ 116 | 1.5 ~ 8.16 | N/A | N/A | Doble aire con retorno por resorte |

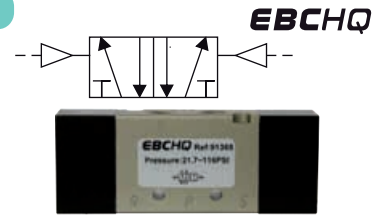
VÁLVULAS
DIRECCIONALES NEUMÁTICAS 5/3

| REF | PUERTO | DIÁMETRO NOMINAL | CV | PRESIÓN DE TRABAJO | | OPERACIÓN | TIPO CENTROS |
|-------|----------|------------------|------|--------------------|--------------------|------------------------------------|--------------|
| | | | | psi | kg/cm ² | | |
| 91397 | 1/8" NPT | 6 mm | 0.67 | 21 ~ 116 | 1.5 ~ 8.16 | Doble aire con retorno por resorte | Cerrados |
| 91400 | | | | | | | Abiertos |

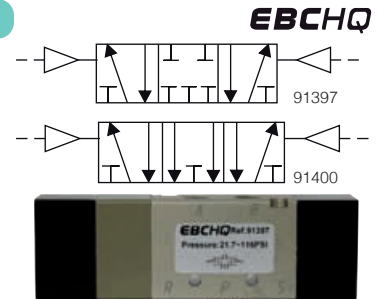
VÁLVULAS
MANIFOLD PARA VÁLVULAS 3/2

| REF | PUERTO | ESTACIONES | TAMAÑO VÁLVULAS | MEDIDAS (mm) | MATERIAL |
|-------|----------|------------|--------------------------|---------------|------------------------------------|
| 91410 | 1/4" NPT | 4 | Máximo 22 mm de ancho | 45 x 108 x 24 | Bloque en Aluminio y sellos en NBR |
| 91411 | | 6 | | 45 x 154 x 24 | |
| 91412 | | 8 | | 45 x 200 x 24 | |
| 91413 | | 10 | | 45 x 246 x 24 | |

VÁLVULAS
MANIFOLD PARA VÁLVULAS 5/2

| REF | PUERTO | ESTACIONES | TAMAÑO VÁLVULAS | MEDIDAS (mm) | MATERIAL |
|-------|----------|------------|--------------------------|---------------|------------------------------------|
| 91420 | 1/4" NPT | 3 | Máximo 22 mm de ancho | 60 x 92 x 22 | Bloque en Aluminio y sellos en NBR |
| 91421 | | 4 | | 60 x 115 x 22 | |
| 91422 | | 5 | | 60 x 138 x 22 | |
| 91423 | | 6 | | 60 x 161 x 22 | |
| 91424 | | 8 | | 60 x 207 x 22 | |
| 91425 | | 10 | | 60 x 253 x 22 | |
| 91426 | | 12 | | 60 x 299 x 22 | |

VÁLVULAS
ACCESORIOS VÁLVULAS SOLENOIDES
KIT DE SPOOL Y SELLOS (O´RING)

| REF | PARA VÁLVULA | REPUESTO PARA VÁLVULAS REFERENCIAS | MATERIAL |
|-------|--------------|---|---|
| 91372 | 3/2 | 91280 a 91283 y 91293 a 91296 | Sellos (O´ring) en NBR, spool en Aluminio |
| 91373 | 5/2 | 91319 a 91322 - 91343 a 91346 - 91330 a 91333 y 91352 a 91355 | |

BOBINA Y CONECTOR CON INDICADOR LED

| REF | VOLTAJE | MÁXIMAS OPERACIONES | TIPO CONECTOR | USO | PROTECCIÓN |
|-------|---------|---------------------|---------------|---------------------|------------|
| 91391 | 24V DC | 5 ciclos/s | DIN | Valvulas Solenoides | IP65 |
| 91392 | 110V AC | | | | |
| 91393 | 220V AC | | | | |



CE

VÁLVULAS MANUALES
ROTATIVAS 4/2, SERIE 4HV
EBCHQ SNS

| REF | PUERTO | ÁREA EFECTIVA | CV | PRESIÓN DE TRABAJO | | OPERACIÓN | MATERIAL |
|-------|----------|--------------------|------|--------------------|--------------------|----------------|------------------------------------|
| | | | | psi | kg/cm ² | | |
| 91440 | 1/4" NPT | 33 mm ² | 1.67 | 0 ~ 145 | 0 ~ 10 | Palanca manual | Cuerpo en aluminio sellos en Nylon |
| 91442 | 3/8" NPT | | 1.83 | | | | |
| 91444 | 1/2" NPT | 88 mm ² | 4.89 | | | | |

VÁLVULAS MANUALES
ROTATIVAS 4/2, SERIE HV
EBCHQ SNS

| REF | PUERTO | ÁREA EFECTIVA | CV | PRESIÓN DE TRABAJO | | OPERACIÓN | MATERIAL |
|-------|----------|--------------------|------|--------------------|--------------------|----------------|--|
| | | | | psi | kg/cm ² | | |
| 91460 | 1/4" NPT | 16 mm ² | 0.89 | 0 ~ 116 | 0 ~ 8.2 | Palanca manual | Cuerpo en aleación de aluminio sellos en NBR |
| 91461 | 3/8" NPT | 33 mm ² | 1.83 | | | | |
| 91462 | 1/2" NPT | 88 mm ² | 4.89 | | | | |

VÁLVULAS MANUALES
BOTÓN 3/2 NC, SERIE 4R
EBCHQ SNS

| REF | PUERTO | ÁREA EFECTIVA | CV | PRESIÓN DE TRABAJO | | OPERACIÓN | MATERIAL |
|-------|----------|--------------------|------|--------------------|--------------------|-----------------------|--|
| | | | | psi | kg/cm ² | | |
| 91470 | 1/8" NPT | 16 mm ² | 0.89 | 0 ~ 116 | 0 ~ 8.2 | Botón de 2 posiciones | Cuerpo en aleación de aluminio sellos en NBR |
| 91472 | 1/4" NPT | | | | | | |
| 91474 | 3/8" NPT | 25 mm ² | 1.40 | | | | |
| 91476 | 1/2" NPT | 30 mm ² | 1.68 | | | | |

VÁLVULAS MANUALES
PALANCA 5/2, SERIE 4H
EBCHQ SNS

| REF | PUERTO | ÁREA EFECTIVA | CV | PRESIÓN DE TRABAJO | | OPERACIÓN | MATERIAL |
|-------|----------|--------------------|------|--------------------|--------------------|----------------|--|
| | | | | psi | kg/cm ² | | |
| 91486 | 1/4" NPT | 16 mm ² | 0.89 | 0 ~ 116 | 0 ~ 8.2 | Palanca manual | Cuerpo en aleación de aluminio sellos en NBR |
| 91488 | 3/8" NPT | 25 mm ² | 1.40 | | | | |
| 91490 | 1/2" NPT | 30 mm ² | 1.68 | | | | |

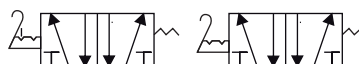
VÁLVULAS MANUALES
PEDAL 5/2, SERIE FOV
EBCHQ SNS

| REF | PUERTO | ÁREA EFECTIVA | CV | PRESIÓN DE TRABAJO | | MATERIAL | OPERACIÓN TIPO |
|-------|----------|------------------------------|------|--------------------|--------------------|--|--------------------|
| | | | | psi | kg/cm ² | | |
| 91495 | 1/4" NPT | 24 mm ² | 1.20 | 0 ~ 116 | 0 ~ 8.2 | Cuerpo en aleación de aluminio cobertor plástico sellos en NBR | Pedal |
| 91498 | | | | | | | Pedal con cobertor |
| 91496 | 3/8" NPT | Pedal con enclavamiento | | | | | |
| 91499 | | Pedal enclavamiento cobertor | | | | | |



VÁLVULAS MANUALES
PEDAL 5/2, SERIE ST
EBCHQ SNS

| REF | PUERTO | ÁREA EFECTIVA | CV | PRESIÓN DE TRABAJO | | MATERIAL | OPERACIÓN TIPO |
|-------|----------|------------------------|------|--------------------|--------------------|--|------------------------|
| | | | | psi | kg/cm ² | | |
| 91501 | 1/4" NPT | 24 mm ² | 1.20 | 0 ~ 116 | 0 ~ 8.2 | Cuerpo en aleación de aluminio sellos en NBR | Pedal fijo |
| 91502 | | | | | | | Pedal/ retorno resorte |
| 91504 | 3/8" NPT | Pedal fijo | | | | | |
| 91505 | | Pedal/ retorno resorte | | | | | |

VÁLVULAS MANUALES
CORREDERA 3/2

| REF | PUERTO | ÁREA EFECTIVA | CV | PRESIÓN DE TRABAJO | | OPERACIÓN | MATERIAL |
|-------|----------|--------------------|------|--------------------|--------------------|--------------------------|--------------------------------|
| | | | | psi | kg/cm ² | | |
| 85600 | 1/8" NPT | 6 mm ² | 0,33 | 0 ~ 142 | 0 ~ 10 | Manual por deslizamiento | Cuerpo en Bronce sellos en NBR |
| 85602 | 1/4" NPT | 8 mm ² | 0,44 | | | | |
| 85603 | 3/8" NPT | 10 mm ² | 0,55 | | | | |
| 85604 | 1/2" NPT | 15 mm ² | 0,83 | | | | |

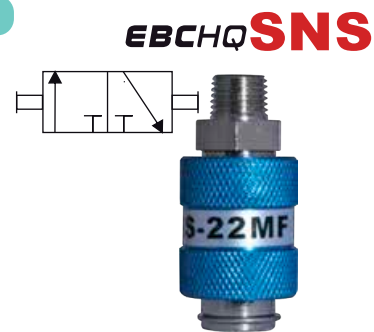
Protección IP65

VÁLVULAS MANUALES
ANTIRRETORNO SERIE CV

| REF | PUERTO | ÁREA EFECTIVA | CV | PRESIÓN DE TRABAJO | | MATERIAL | PROTECCIÓN |
|-------|----------|--------------------|------|--------------------|--------------------|--------------------------------|------------|
| | | | | psi | kg/cm ² | | |
| 85608 | 1/8" NPT | 6 mm ² | 0,33 | 0 ~ 142 | 0 ~ 10 | Cuerpo en Bronce sellos en NBR | IP65 |
| 85609 | 1/4" NPT | 8 mm ² | 0,44 | | | | |
| 85610 | 3/8" NPT | 10 mm ² | 0,55 | | | | |
| 85611 | 1/2" NPT | 15 mm ² | 0,83 | | | | |

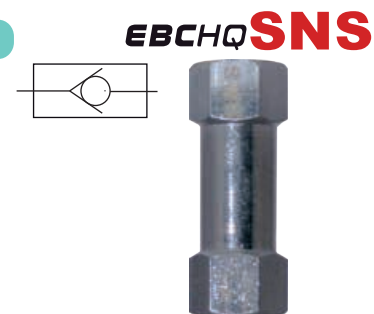
VÁLVULAS MANUALES
ANTIRRETORNO SERIE LCV

| REF | PUERTO | ÁREA EFECTIVA | CV | PRESIÓN DE TRABAJO | | MATERIAL | PROTECCIÓN |
|-------|----------|--------------------|------|--------------------|--------------------|--|------------|
| | | | | psi | kg/cm ² | | |
| 85615 | 1/8" NPT | 6 mm ² | 0,33 | 4 ~ 135 | 0,3 ~ 9,5 | Cuerpo en aleación de aluminio sellos en NBR | IP65 |
| 85616 | 1/4" NPT | 8 mm ² | 0,44 | | | | |
| 85613 | 3/8" NPT | 10 mm ² | 0,55 | | | | |
| 85614 | 1/2" NPT | 15 mm ² | 0,83 | | | | |

VÁLVULAS MANUALES
CONTROL DE FLUJO SERIE AS

| REF | PUERTO | ÁREA EFECTIVA | CV | PRESIÓN DE TRABAJO | | MATERIAL | PROTECCIÓN |
|-------|----------|----------------------|------|--------------------|--------------------|--|------------|
| | | | | psi | kg/cm ² | | |
| 85617 | 1/4" NPT | 5.2 mm ² | 0,26 | 0 ~ 142 | 0 ~ 10 | Cuerpo en aleación de aluminio sellos en NBR | IP65 |
| 85618 | 3/8" NPT | 12.3 mm ² | 0,61 | | | | |
| 85619 | 1/2" NPT | 25.5 mm ² | 1,27 | | | | |



VÁLVULAS MANUALES
CONTROL DE FLUJO SERIE ASC

| REF | PUERTO | ÁREA EFECTIVA | CV | PRESIÓN DE TRABAJO | | MATERIAL | PROTECCIÓN |
|-------|----------|----------------------|------|--------------------|--------------------|--|------------|
| | | | | psi | kg/cm ² | | |
| 85620 | 1/8" NPT | 3.8 mm ² | 0,19 | 0 ~ 142 | 0 ~ 10 | Cuerpo en aleación de aluminio sellos en NBR | IP65 |
| 85621 | 1/4" NPT | 6.0 mm ² | 0,30 | | | | |
| 85622 | 3/8" NPT | 32.0 mm ² | 1,60 | | | | |
| 85623 | 1/2" NPT | 32.8 mm ² | 1,64 | | | | |

VÁLVULAS MANUALES
CONTROL DE FLUJO SERIE RE

| REF | PUERTO | ÁREA EFECTIVA | CV | PRESIÓN DE TRABAJO | | MATERIAL | PROTECCIÓN |
|-------|----------|---------------------|------|--------------------|--------------------|--|------------|
| | | | | psi | kg/cm ² | | |
| 85626 | 1/8" NPT | 3.8 mm ² | 0,19 | 0 ~ 142 | 0 ~ 10 | Cuerpo en aleación de aluminio sellos en NBR | IP65 |
| 85627 | 1/4" NPT | 6.0 mm ² | 0,30 | | | | |

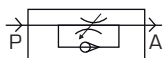



VÁLVULAS MANUALES

CONTROL DE FLUJO SERIE ASC

EBCHQ SNS

| REF | PUERTO | ÁREA EFECTIVA | CV | PRESIÓN DE TRABAJO | | MATERIAL | PROTECCIÓN |
|-------|----------|---------------------|------|--------------------|--------------------|--|------------|
| | | | | psi | kg/cm ² | | |
| 85630 | 1/8" NPT | 3.8 mm ² | 0,19 | 7 ~ 135 | 0.5 ~ 9.5 | Cuerpo en aleación de aluminio sellos en NBR | IP65 |
| 85631 | 1/4" NPT | 6.0 mm ² | 0,30 | | | | |

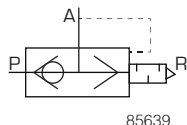

85639

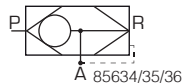

85634/35/36



VÁLVULAS MANUALES

ESCAPE RÁPIDO SERIES SEU Y BQE

EBCHQ SNS

| REF | PUERTO | ÁREA EFECTIVA | CV | PRESIÓN DE TRABAJO | | MATERIAL | PROTECCIÓN |
|-------|----------|----------------------|------|--------------------|--------------------|--|------------|
| | | | | psi | kg/cm ² | | |
| 85639 | 1/2" NPT | 106 mm ² | 5,59 | 7 ~ 135 | 0.5 ~ 9.5 | Cuerpo en aleación de aluminio sellos en NBR | IP65 |
| 85634 | 1/4" NPT | 6.0 mm ² | 0,30 | | | | |
| 85635 | 3/8" NPT | 32.0 mm ² | 1,60 | 0 ~ 142 | 0 ~ 10 | | |
| 85636 | 1/2" NPT | 32.8 mm ² | 1,64 | | | | |

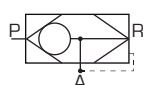

VÁLVULAS MANUALES

ESCAPE RÁPIDO SERIE QE

EBCHQ SNS

| REF | PUERTO | ÁREA EFECTIVA | CV | PRESIÓN DE TRABAJO | | MATERIAL | PROTECCIÓN |
|-------|----------|----------------------|------|--------------------|--------------------|--|------------|
| | | | | psi | kg/cm ² | | |
| 85640 | 1/8" NPT | 3.8 mm ² | 0,19 | 0 ~ 142 | 0 ~ 10 | Cuerpo en aleación de aluminio sellos en NBR | IP65 |
| 85641 | 1/4" NPT | 6.0 mm ² | 0,30 | | | | |
| 85642 | 3/8" NPT | 32.0 mm ² | 1,60 | | | | |
| 85643 | 1/2" NPT | 32.8 mm ² | 1,64 | | | | |

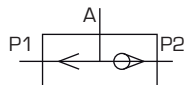

VÁLVULAS MANUALES

ESCAPE RÁPIDO SERIE KV

EBCHQ SNS

| REF | PUERTO | ÁREA EFECTIVA | CV | PRESIÓN DE TRABAJO | | MATERIAL | PROTECCIÓN |
|-------|----------|--------------------|------|--------------------|--------------------|--|------------|
| | | | | psi | kg/cm ² | | |
| 85650 | 1/8" NPT | 10 mm ² | 0,56 | 0 ~ 142 | 0 ~ 10 | Cuerpo en aleación de aluminio sellos en NBR | IP65 |
| 85651 | 1/4" NPT | | | | | | |
| 85652 | 3/8" NPT | 21 mm ² | 1,17 | | | | |
| 85653 | 1/2" NPT | | | | | | |



86585



86588



VÁLVULAS MANUALES

CODILLO SERIE HL

EBCHQ SNS

| REF | PUERTO | ÁREA EFECTIVA | CV | PRESIÓN DE TRABAJO | | MATERIAL | PROTECCIÓN |
|-------|-----------------|--------------------|------|--------------------|--------------------|--|------------|
| | | | | psi | kg/cm ² | | |
| 85685 | 5/2 1/8" NPT | 16 mm ² | 0,89 | 0 ~ 116 | 0 ~ 8 | Cuerpo en aleación de aluminio sellos en NBR | IP65 |
| 85688 | 3/2 1/4" NPT | | | | | | |

NEUMÁTICA

| REF | TIPO | DIÁMETRO NOMINAL | CV | PRESIÓN DE TRABAJO | | PUERTOS | MATERIAL |
|-------|--------------------------------|--------------------|------|--------------------|--------------------|----------|--|
| | | | | psi | kg/cm ² | | |
| 85670 | Selector de muletilla (2 Pos) | 24 mm ² | 1,20 | 0 ~ 116 | 0 ~ 8 | 1/8" NPT | Cuerpo en aleación de aluminio sellos en NBR |
| 85672 | Final de carrera | | | | | | |
| 85674 | Pulsador/ paro emergencia | | | | | | |
| 85676 | Pulsador (retorno por resorte) | | | | | | |

Protección IP 65

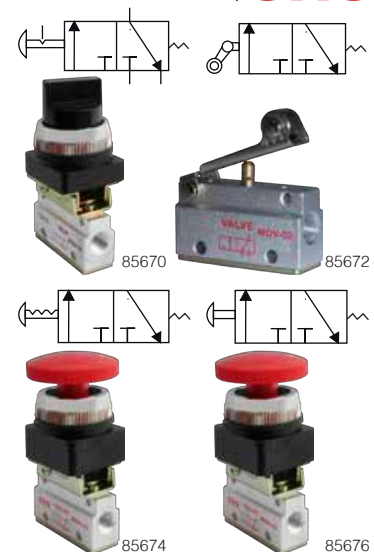

| REF | TIPO | DIÁMETRO NOMINAL | CV | PRESIÓN DE TRABAJO | | PUERTOS | MATERIAL |
|-------|--------------------------------|--------------------|------|--------------------|--------------------|----------|--|
| | | | | psi | kg/cm ² | | |
| 85679 | Selector de muletilla (2 Pos) | 24 mm ² | 1,20 | 0 ~ 116 | 0 ~ 8 | 1/4" NPT | Cuerpo en aleación de aluminio sellos en NBR |
| 85682 | Final de carrera | | | | | | |
| 85680 | Pulsador/ paro emergencia | | | | | | |
| 85681 | Pulsador (retorno por resorte) | | | | | | |

Protección IP 65

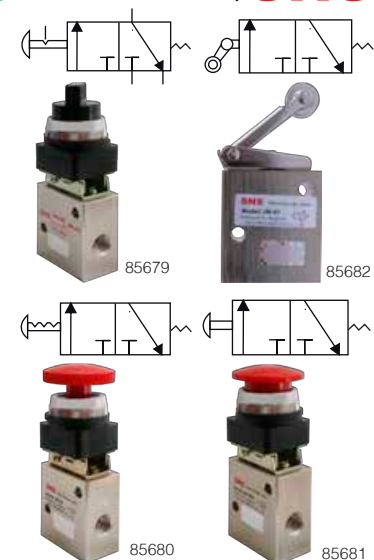

| REF | TIPO | DIÁMETRO NOMINAL | CV | PRESIÓN DE TRABAJO | | PUERTOS | MATERIAL |
|-------|--------------------------------|--------------------|------|--------------------|--------------------|----------|--|
| | | | | psi | kg/cm ² | | |
| 85690 | Selector de muletilla (2 Pos) | 24 mm ² | 1,20 | 0 ~ 116 | 0 ~ 8 | 1/4" NPT | Cuerpo en aleación de aluminio sellos en NBR |
| 85692 | Final de carrera | | | | | | |
| 85694 | Pulsador/ paro emergencia | | | | | | |
| 85696 | Pulsador (retorno por resorte) | | | | | | |

Protección IP 65

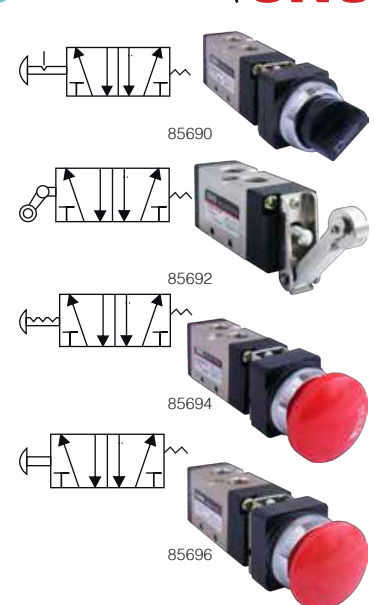

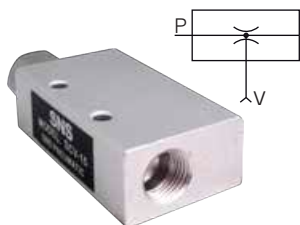

| REF | PUERTO | DIÁMETRO BOQUILLA | FLUJO MÁX. (L/MIN) | VACÍO | | OPERACIÓN | MATERIAL |
|-------|----------|-------------------|--------------------|---------|--------------------|-----------------|--|
| | | | | psi | kg/cm ² | | |
| 86805 | 1/8" NPT | 1.0 mm | 36 | -3 a -8 | -0.21 a -0.56 | 14 psi a 90 psi | Cuerpo en aleación de aluminio sellos en NBR |
| 86807 | 1/4" NPT | 1.5 mm | 95 | | | | |
| 86809 | 3/8" NPT | 2.0 mm | 110 | | | | |

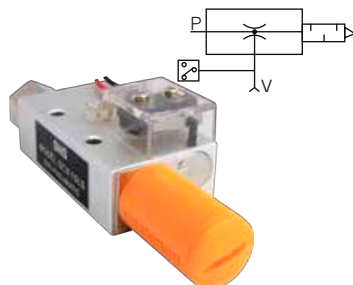

| REF | PUERTO | DIÁMETRO BOQUILLA | FLUJO MÁX. (L/MIN) | VACÍO | | OPERACIÓN | MATERIAL |
|-------|----------|-------------------|--------------------|---------|--------------------|-----------------|--|
| | | | | psi | kg/cm ² | | |
| 86815 | 1/8" NPT | 1.0 mm | 36 | -3 a -8 | -0.21 a -0.56 | 14 psi a 90 psi | Cuerpo en aleación de aluminio sellos en NBR |
| 86817 | 1/4" NPT | 1.5 mm | 95 | | | | |
| 86819 | 3/8" NPT | 2.0 mm | 110 | | | | |

Con microswitch para ajustar el valor del vacío

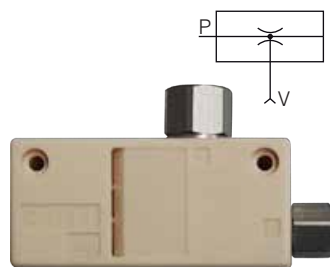

| REF | PUERTO | DIÁMETRO BOQUILLA | FLUJO MÁX. (L/MIN) | VACÍO | | OPERACIÓN | MATERIAL |
|-------|-----------------|-------------------|--------------------|---------|--------------------|-----------------|-------------------------------|
| | | | | psi | kg/cm ² | | |
| 86823 | 1/8" NPT | 1.0 mm | 24 | -3 a -7 | -0.21 a -0.49 | 14 psi a 90 psi | Cuerpo plástico sellos en NBR |
| 86825 | 1/8" y 1/4" NPT | 1.5 mm | 40 | | | | |

Coeficiente de Flujo de Válvulas (Kv, Cv, Qn)

Cuando un flujo pasa a través de una válvula o cualquier dispositivo restrictor del flujo, este pierde algo de energía. El coeficiente de flujo es un factor diseñado que relaciona la caída de presión (ΔP) con el caudal ó flujo Q. Cada válvula tiene su propio coeficiente de flujo. Esto depende de cómo la válvula fue diseñada para dejar pasar el flujo a través de ella. Por lo tanto, las principales diferencias entre los diferentes coeficientes de flujo vienen dados por el tipo de válvula y la posición de apertura de la válvula. El coeficiente de flujo es importante a la hora de seleccionar la mejor válvula para una aplicación específica.

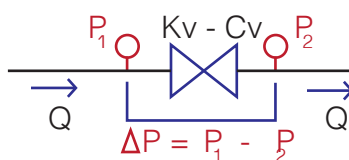

Entonces:

¿Qué es el valor Kv?

En los países que emplean unidades métricas se suele utilizar el coeficiente Kv el cual está definido por la norma IEC 534-1987 de válvulas de control del siguiente modo:

"Caudal de agua (de 5 a 40°C) en m³/h que pasa a través de la válvula a una apertura dada y con una pérdida de 1 bar (1.02 Kg/cm²)".

El Kv de una válvula es un coeficiente experimental basado en condiciones de laboratorio

¿Qué es el valor Cv?

Es el equivalente al Kv, pero en galones por minuto, se define como:

"Caudal de agua en galones USA por minuto que pasa a través de la válvula en posición completamente abierta a la temperatura entre 5°C y 40°C con una caída de presión a través de la válvula toda abierta de 1 Psi".

¿Qué es el valor Qn?

El Qn (Caudal Nominal) es usado en neumática para definir el flujo de una válvula, se define como:

"El flujo volumétrico en litros por minuto de aire a 20°C de temperatura, con una presión de entrada de 6 bares y una caída de presión de 1 bar a través de la válvula".

Equivalencias entre Kv, Cv & Qn

$$Kv = 0.86 \times Cv \text{ (M}^3\text{/hora)}$$

$$Kv = Qn / 1078$$

$$Cv = Kv \times 1.163 \text{ (Galones x Minuto)}$$

$$Cv = Qn \times 0.0008$$

$$Qn = Kv \times 1078$$

$$Qn = Cv / 0.0008$$

Cálculos útiles

La fuerza teórica del cilindro se calcula multiplicando el área efectiva del pistón por la presión de trabajo.

El área efectiva para el cilindro "A+" (Salida) es el área completa del diámetro "D" cilindro.

El área efectiva del cilindro "A-" (Entrada) se reduce por el área del vástago del pistón "d".

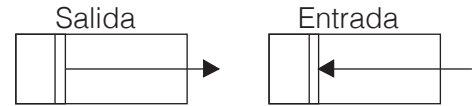
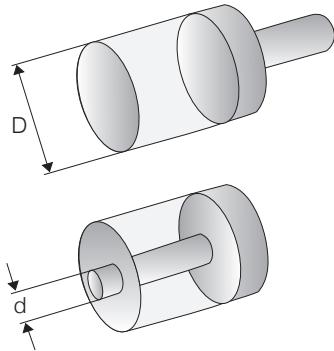

$$F_{\text{Salida}} [\text{N}] = \pi \frac{D_{\text{cil}}^2}{4} [\text{mm}^2] \frac{P [\text{bar}]}{10}$$

P manométrica

$$F_{\text{Entrada}} [\text{N}] = \pi \frac{D_{\text{cil}}^2 - d_{\text{vas}}^2}{4} [\text{mm}^2] \frac{P [\text{bar}]}{10}$$

$$1 \text{ bar} = 10^5 \text{ Pa} = 10^5 \frac{\text{N}}{\text{m}^2} = 10^5 \frac{\text{N}}{\text{m}^2} \left[\frac{\text{m}^2}{10^6 \text{ mm}^2} \right] = 0,1 \frac{\text{N}}{\text{mm}^2}$$

Empuje/Extensión

Salida- $F = \frac{\pi \times D^2 \times P}{40}$

Arrastre/Retracción

Entrada- $F = \frac{\pi (D^2 - d^2) \times P}{40}$

La fricción interna y las pérdidas deben ser tenidas en cuenta dado que normalmente reduce la fuerza teórica en un 20%. En aplicaciones cíclicas rápidas, la fuerza teórica se reduce en un 30%.

Fuerza Teórica (Kgf)

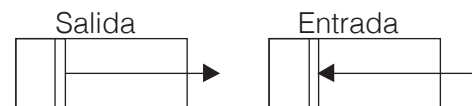

| DIÁMETRO CILINDRO D (mm) | Ø del VASTAGO d (mm) | SENTIDO DEL MOVIMIENTO | ÁREA EFECTIVA (mm²) | Presión de Trabajo (Kgf/cm²) | | | | | | | | |
|--------------------------|----------------------|------------------------|---------------------|------------------------------|--------|--------|--------|--------|--------|--------|--------|---------|
| | | | | 1 | 2 | 3 | 4 | 5 | 6 | 7 | 8 | 9 |
| 16 | 6 | Salida | 201 | 2,01 | 4,02 | 6,03 | 8,04 | 10,05 | 12,06 | 14,07 | ----- | ----- |
| | | Entrada | 181 | 1,81 | 3,62 | 5,43 | 7,24 | 9,05 | 10,86 | 12,67 | ----- | ----- |
| 20 | 8 | Salida | 314 | 3,14 | 6,28 | 9,42 | 12,56 | 15,7 | 16,84 | 21,98 | 25,12 | 28,26 |
| | | Entrada | 264 | 2,64 | 5,28 | 7,92 | 10,56 | 13,2 | 15,84 | 18,48 | 21,12 | 23,76 |
| 25 | 10 | Salida | 490 | 4,90 | 9,80 | 14,70 | 19,6 | 24,5 | 29,4 | 34,3 | 39,2 | 44,1 |
| | | Entrada | 412 | 4,12 | 8,24 | 12,36 | 16,48 | 20,6 | 24,72 | 28,84 | 32,96 | 37,08 |
| 32 | 12 | Salida | 804 | 8,04 | 16,08 | 24,12 | 32,16 | 40,2 | 48,24 | 56,28 | 64,32 | 72,36 |
| | | Entrada | 691 | 6,09 | 13,80 | 20,70 | 27,6 | 34,5 | 41,4 | 48,3 | 55,2 | 62,1 |
| 40 | 16 | Salida | 1257 | 12,56 | 25,12 | 37,68 | 50,24 | 62,8 | 75,36 | 87,92 | 100,24 | 113,04 |
| | | Entrada | 1056 | 10,55 | 21,10 | 34,65 | 42,2 | 52,75 | 63,3 | 73,85 | 84,4 | 94,95 |
| 50 | 20 | Salida | 1963 | 19,63 | 39,26 | 58,89 | 78,52 | 98,15 | 117,78 | 137,41 | 157,04 | 176,67 |
| | | Entrada | 1649 | 16,49 | 32,98 | 49,47 | 65,96 | 82,45 | 98,94 | 115,43 | 139,92 | 148,41 |
| 63 | 20 | Salida | 3117 | 31,17 | 62,34 | 93,51 | 124,68 | 155,85 | 187,02 | 218,19 | 249,36 | 280,53 |
| | | Entrada | 2803 | 28,03 | 56,06 | 84,09 | 112,12 | 140,15 | 168,18 | 196,21 | 224,24 | 252,27 |
| 80 | 25 | Salida | 5027 | 50,26 | 100,52 | 150,78 | 201,04 | 251,3 | 301,56 | 351,82 | 402,08 | 452,34 |
| | | Entrada | 4536 | 45,36 | 90,72 | 136,08 | 181,44 | 226,8 | 272,16 | 317,82 | 362,88 | 408,24 |
| 100 | 25 | Salida | 7854 | 78,53 | 157,06 | 235,59 | 314,12 | 392,65 | 471,18 | 549,71 | 628,24 | 706,77 |
| | | Entrada | 7147 | 71,47 | 142,94 | 214,41 | 282,88 | 357,35 | 428,82 | 500,29 | 571,76 | 643,23 |
| 125 | 32 | Salida | 1227,2 | 122,72 | 245,44 | 368,16 | 490,88 | 613,6 | 736,32 | 859,04 | 981,76 | 1104,48 |
| | | Entrada | 1146,8 | 114,68 | 229,36 | 344,04 | 458,72 | 573,4 | 688,08 | 802,76 | 917,44 | 1032,12 |

NOTA: Fuerza teorica (Kgf) = Presión (Kgf/cm²) x Área Cilindro (cm²)

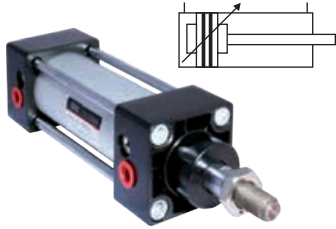

| DIÁMETRO (mm) | PUERTOS | ROSCA DEL VÁSTAGO | CARRERA (mm) | | | FUERZA TEÓRICA (Kg) | OPERACIÓN |
|---------------|----------|-------------------|--------------|--------------|--------------|---------------------|------------------|
| | | | 50 | 100 | 150 | | |
| 32 | 1/8" NPT | M10 x 1.25 | 85100 | 85102 | 85104 | 70 máx. | 14 psi a 130 psi |

Amortiguación regulable en ambos lados, anillo magnético estándar
Cuerpo en aleación de aluminio sellos en NBR

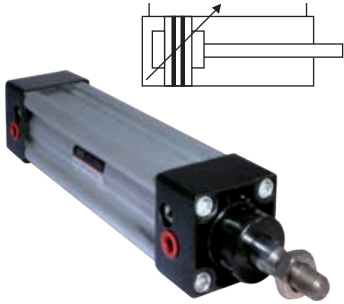

| DIÁMETRO (mm) | PUERTOS | ROSCA DEL VÁSTAGO | CARRERA (mm) | | | | | | | FUERZA TEÓRICA(Kg) | |
|---------------|----------|-------------------|--------------|--------------|--------------|--------------|--------------|--------------|--------------|--------------------|----------|
| | | | 25 | 50 | 100 | 150 | 200 | 250 | 300 | | 350 |
| 32 | 1/8" NPT | M10 x 1.25 | 85108 | 85110 | 85114 | 85116 | 85118 | | | 85121 | 70 máx. |
| 40 | 1/4" NPT | M12 x 1.25 | | | 85124 | 85126 | 85128 | | | | 110 máx. |
| 50 | | | M16 x 1.5 | | | 87120 | 87122 | | | | 170 máx. |
| 63 | 3/8" NPT | M16 x 1.5 | | | | 87126 | 87128 | | | | 280 máx. |
| 80 | | | M20 x 1.5 | | | | | 87135 | 87136 | | 450 máx. |
| 100 | 1/2" NPT | M20 x 1.5 | | | | | | 87140 | | | 700 máx. |

Amortiguación regulable en ambos lados, anillo magnético estándar
Cuerpo en aleación de aluminio sellos en NBR. Operación 14psi a 130psi

| LB Pies | CB Base con Pivote | CA Base con Horquilla | FA/FB Flanche | Y Horquilla "Y" | I Horquilla "I" | FJ - 11 Rotula Frontal | FJ - 10 Auto Alineador |
|------------|-----------------------|--------------------------|------------------|--------------------|--------------------|---------------------------|---------------------------|
| | | | | | | | |

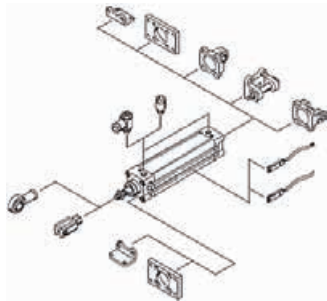

| DIÁMETRO (mm) | ROSCA DEL VÁSTAGO | LB | CB | CA | FA/FB | Y | I | FJ-11 | FJ-10 | DESCRIPCIÓN | | |
|---------------|-------------------|--------------|--------------|--------------|--------------|--------------|--------------|----------------|----------------|--------------|---------------------|-----------------------|
| | | | | | | | | | | LB | Base para cilindros | |
| 32 | M10 x 1.25 | 85130 | 85132 | 85134 | 85136 | 85138 | 85140 | 85142 | 85144 | CB | Base con pivote | |
| 40 | M12 x 1.25 | 85131 | 85133 | 85135 | 85137 | 85190 | 85141 | 85192 | 85193 | CA | Base con horquilla | |
| 50 | M16 x 1.5 | 87200 | 87215 | 87222 | 87242 | | | 87235 | 85192-1 | 85194 | FA/FB | Flanche |
| 63 | | 87201 | 87216 | 87223 | 87243 | | | | | | Y | Horquilla frontal "Y" |
| 80 | M20 x 1.5 | 87202 | 87217 | 87224 | 87244 | | | | | | I | Horquilla frontal "I" |
| 100 | | 87203 | | 87225 | 87245 | | 87236 | 85192-2 | 85195 | | FJ-11 | Rotula frontal |
| 125 | M27 x 2.0 | | | | | 87484 | 87237 | | 85196 | | FJ-10 | Autoalineador |



| DIÁMETRO (mm) | PUERTOS | ROSCA DEL VÁSTAGO | CARRERA (mm) | | | | | | | | | FUERZA TEORICA (Kg) |
|---------------|----------|-------------------|--------------|-------|-------|-------|-------|-------|-------|-------|------|---------------------|
| | | | 50 | 80 | 100 | 125 | 150 | 200 | 250 | 500 | 1000 | |
| 32 | 1/8" NPT | M10 x 1.25 | 85156 | 85157 | 85158 | 85159 | 85160 | 85161 | 85162 | 85163 | | 70 máx. |
| 40 | 1/4" NPT | M12 x 1.25 | 85165 | 85166 | 85170 | 85171 | 85173 | 85176 | 85177 | 85180 | | 110 máx. |
| 50 | | M16 x 1.5 | 87300 | 87302 | 87304 | 87306 | 87308 | 87310 | 87312 | 87314 | | 170 máx. |
| 63 | 3/8" NPT | M16 x 1.5 | 87325 | 87327 | 87329 | 87331 | 87333 | 87335 | 87337 | | | 280 máx. |
| 80 | | | | 87340 | 87342 | 87344 | 87346 | 87348 | | 87350 | | 450 máx. |
| 100 | 1/2" NPT | M20 x 1.5 | | 87355 | 87357 | 87359 | 87361 | 87363 | | | | 700 máx. |
| 125 | | M27 x 2.0 | 87367 | 87369 | 87371 | 87373 | 87375 | 87376 | | | | 1050 máx. |

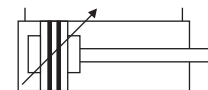

Amortiguación regulable en ambos lados, anillo magnético estándar

Cuerpo en aleación de aluminio sellos en NBR. Operación 14psi a 130psi

ACCESORIOS PARA CILINDROS ISO6431 SERIE TGD o DNC

| LB Pies | CB Base con Pivote | CA Base con Horquilla | FA/FB Flanche | SDB Base horquilla inclinada | Y Horquilla "Y" | I Horquilla "I" | FJ - 11 Rotula Frontal | FJ - 10 Auto Alineador |
|------------|-----------------------|--------------------------|------------------|---------------------------------|--------------------|--------------------|---------------------------|---------------------------|
| | | | | | | | | |

| DIÁMETRO (mm) | ROSCA DEL VÁSTAGO | LB | CB | CA | SDB | FA/FB | Y | I | FJ-11 | FJ-10 | DESCRIPCIÓN | |
|---------------|-------------------|-------|-------|---------|-------|---------|-------|-------|---------|-------|-------------|------------------------------|
| | | | | | | | | | | | LB | CB |
| 32 | M10 x 1.25 | 87400 | 87414 | 87424 | 87435 | 87445 | 87480 | 85140 | 87460 | 85144 | LB | Base para cilindros |
| 40 | M12 x 1.25 | 87401 | 87415 | 87424-1 | 87436 | 87445-1 | 87481 | 85141 | 85192 | 85193 | CB | Base con pivote |
| 50 | M16 x 1.5 | 87402 | 87416 | 87425 | | 87446 | | | | | CA | Base con horquilla |
| 63 | | 87403 | 87417 | 87426 | | 87447 | 87482 | 87235 | 85192-1 | 85194 | SDB | Base con horquilla inclinada |
| 80 | M20 x 1.5 | 87404 | 87418 | 87427 | | 87448 | | | | | FA/FB | Flanche |
| 100 | | 87405 | 87419 | 87428 | | 87449 | 87483 | 87236 | 85192-2 | 85195 | Y | Horquilla frontal "Y" |
| 125 | M27 x 2.0 | | | | | | 87484 | 87237 | | 85196 | I | Horquilla frontal "I" |
| | | | | | | | | | | | FJ-11 | Rotula frontal |
| | | | | | | | | | | | FJ-10 | Autoalineador |

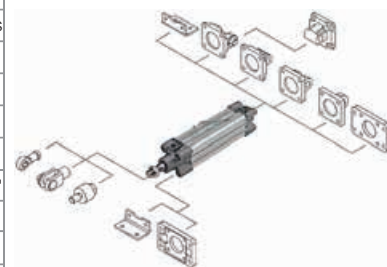

| REF | DIÁMETRO (mm) | PUERTOS | ROSCA DEL VÁSTAGO | PARTES | | FUERZA TEÓRICA(Kg) |
|-------|---------------|----------|-------------------|-------------------------|---------------------------|--------------------|
| 87381 | 32 | 1/8" NPT | M10 x 1.25 | 1 Piston rod nut | 2 Piston rod (No include) | 70 máx. |
| 87382 | 40 | 1/4" NPT | M12 x 1.25 | 3 Front cover seal ring | 4 Bearing | 110 máx. |
| 87383 | 50 | | | 5 Front cover | 6 Buffering o-ring | 170 máx. |
| 87384 | 63 | 3/8" NPT | M16 x 1.5 | 7 O-ring | 8 Piston rod o-ring | 280 máx. |
| 87385 | 80 | | | 9 Piston o-ring | 10 Magnet (Opcional) | 450 máx. |
| Nuevo | 100 | 1/2" NPT | M20 x 1.5 | 11 Wear ring | 12 Barrel (No include) | 700 máx. |
| Nuevo | 125 | | | M27 x 2.0 | 13 Piston | 14 Cushion seal |
| | | | | 15 Cushion needle | 16 Back over | |
| | | | | 17 Hex socket screw | 18 Profile bolt | |

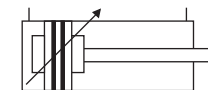

Amortiguación regulable en ambos lados, anillo magnético estándar

Cuerpo en aleación de aluminio sellos en NBR. No incluye camisa exterior ni eje del vástago

NEUMÁTICA

ACTUADORES NEUMÁTICOS

CILINDROS REDONDOS EN ALUMINIO SERIE MAL, DOBLE EFECTO

EBCHQ SNS



| DIÁMETRO (mm) | PUERTOS | ROSCA DEL VÁSTAGO | CARRERA (mm) | | | | | | | | FUERZA TEÓRICA(Kg) | |
|---------------|----------|-------------------|--------------|-------|-------|-------|-------|---------|-------|-----|--------------------|----------|
| | | | 25 | 50 | 60 | 75 | 100 | 200 | 300 | 400 | | |
| 16 | M5 | M 6 x 1 | 85223 | | 85224 | 85225 | 85226 | 85226-1 | | | | 14 máx. |
| 20 | 1/8" NPT | M 8 x 1.25 | 85199 | 85200 | | | 85202 | 85205 | 85207 | | | 28 máx. |
| 25 | | M10 x 1.25 | 85208 | | | | 85211 | 85214 | 87216 | | | 44 máx. |
| 32 | | | | 85218 | 85219 | | | | | | | 70 máx. |
| 40 | 1/4" NPT | M 12 x 1.25 | | | | | | | | | | 110 máx. |

Camisa tubular de aluminio, Anillo magnético estándar

Operación: 14 psi a 130 psi, cuerpo en aleación de aluminio, sellos en NBR

ACTUADORES NEUMÁTICOS

CILINDROS REDONDOS EN ACERO INOX. SERIE MA, DOBLE EFECTO

EBCHQ SNS



| DIÁMETRO (mm) | PUERTOS | ROSCA DEL VÁSTAGO | CARRERA (mm) | | | | | | | | FUERZA TEÓRICA(Kg) | |
|---------------|----------|-------------------|--------------|-------|-------|-------|-------|-------|-------|-------|--------------------|----------|
| | | | 25 | 50 | 75 | 80 | 100 | 150 | 200 | 300 | | |
| 16 | M5 | M 6 x 1 | | | | | | | | | | 14 máx. |
| 20 | 1/8" NPT | M 8 x 1.25 | 85227 | 85228 | 85229 | | 85230 | 85232 | 85234 | 85236 | | 28 máx. |
| 25 | | M10 x 1.25 | 85238 | 85239 | 85240 | 85241 | 85242 | | | | | 44 máx. |
| 32 | | | | 85245 | 85246 | 85247 | 85248 | 85249 | | 85250 | 85251 | |
| 40 | 1/4" NPT | M 12 x 1.25 | | | | | | | | | | 110 máx. |

Camisa tubular de acero inoxidable, anillo magnético estándar

Operación: 14 psi a 130 psi, cuerpo en aleación de aluminio, sellos en NBR

ACTUADORES NEUMÁTICOS

ACCESORIOS PARA CILINDROS MAL/MA

EBCHQ SNS

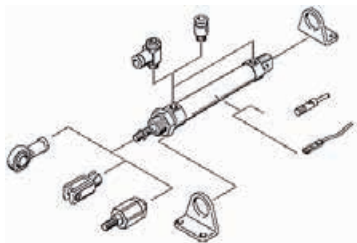

| LB Pies | FA/FB Flanche | BK/PAB 10 Para montaje de sensor | Y Horquilla "Y" | I Horquilla "I" | FJ - 11 Rotula Frontal | FJ - 10 Auto Alineador |
|------------|------------------|-------------------------------------|--------------------|--------------------|---------------------------|---------------------------|
| | | | | | | |

ACCESORIOS PARA CILINDROS REDONDOS SERIE MAL, DOBLE EFECTO

| DIÁMETRO (mm) | ROSCA DEL VÁSTAGO | LB | FA | BK/PAB 10 | Y | I | FJ-11 | FJ-10 | DESCRIPCIÓN | |
|---------------|-------------------|-------|-------|-----------|-------|-------|-------|-------|----------------|-----------------------|
| | | | | | | | | | LB | Base para cilindros |
| 16 | M6 x 1 | 85259 | 85263 | | 85274 | 85281 | | | FA/FB | Flanche |
| 20 | M8 x 1.25 | 85260 | 85264 | 85271 | 85275 | 85282 | 85285 | 85288 | BK/PAB 10 | Para montaje sensor |
| 25 | M10 x 1.25 | | | | 85276 | 85283 | 85142 | 85144 | I | Horquilla frontal "I" |
| 32 | | | | | 85261 | 85265 | | | FJ-11 | Rotula frontal |
| 40 | M12 x 1.25 | | | | | | | FJ-10 | Auto alineador | |

ACTUADORES NEUMÁTICOS

KIT PARA CILINDROS REDONDOS SERIE MAL, DOBLE EFECTO

EBCHQ SNS

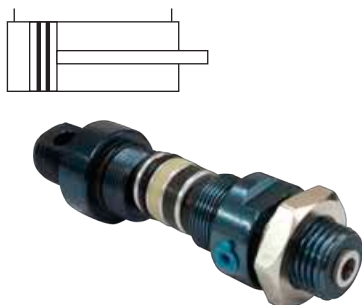

| REF | DIÁMETRO (mm) | PUERTOS | ROSCA DEL VÁSTAGO | PARTES | | FUERZA TEÓRICA(Kg) |
|-------|---------------|----------|-------------------|-------------------------|----------------------------|--------------------|
| | | | | 1 | 2 | |
| 85252 | 16 | M5 | M6 x 1 | 1 Piston rod nut | 2 Piston rod (No include) | 14 máx. |
| 85253 | 20 | 1/8" NPT | M8 x 1.25 | 3 Front cover seal ring | 4 Oiled bearing | 28 máx. |
| 85254 | 25 | | M10 x 1.25 | 5 Front cover | 6 Frond cover | 44 máx. |
| 85255 | 32 | | | 7 Pipe wall o-ring | 8 Alinimum tube (No inclu) | 70 máx. |
| Nuevo | 40 | 1/4" NPT | M12 x 1.25 | 9 Anti-crash cushion | 10 Piston rod o-ring | 110 máx. |
| | | | | 11 Piston o-ring | 12 Piston | |
| | | | | 13 Wear ring | 14 Cushion seal | |
| | | | | 15 Hex socket screw | 16 Back over | |

Para camisa tubular de aluminio, Anillo magnético estándar

Cuerpo en aleación de aluminio sellos en NBR. No incluye camisa exterior ni eje del vástago

ACTUADORES NEUMÁTICOS CILINDROS MULTIMONTAJE SERIE MD, DOBLE EFECTO

| DIÁMETRO (mm) | PUERTOS | ROSCA DEL VÁSTAGO | CARRERA (mm) | | | | | | | | FUERZA TEÓRICA(Kg) | |
|---------------|----------|-------------------|--------------|----|-------|----|----|----|----|----|--------------------|---------|
| | | | 15 | 20 | 25 | 30 | 35 | 40 | 45 | 50 | | |
| 16 | M5 | M5 x 0.8 | | | 85290 | | | | | | 85291 | 14 máx. |
| 20 | | M6 x 1.0 | | | 85293 | | | | | | 85294 | 28 máx. |
| 25 | | M8 x 1.25 | | | 85296 | | | | | | 85297 | 44 máx. |
| 32 | 1/8" NPT | M10 x 1.25 | | | 85300 | | | | | | 85305 | 70 máx. |

Sin amortiguación regulable, anillo magnético estándar

Operación: 14 psi a 130 psi, cuerpo en aleación de aluminio, sellos en NBR

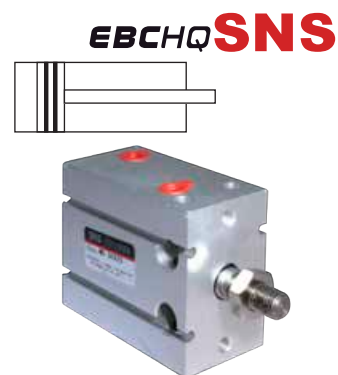
ACTUADORES NEUMÁTICOS CILINDROS DOBLES (TWIN) SERIE TN, DOBLE EFECTO

| DIÁMETRO (mm) | PUERTOS | ROSCA DEL VÁSTAGO | CARRERA (mm) | | | | | | | | FUERZA TEÓRICA(Kg) | |
|---------------|----------|----------------------------|--------------|----|-------|----|----|-------|-------|---------|--------------------|-------------|
| | | | 50 | 60 | 70 | 80 | 90 | 100 | 125 | 150 | | |
| 16 | M5 | N/A (terminación en Placa) | 85335 | | | | | | 85336 | 85336-1 | 85337 | 2 x 14 máx. |
| 20 | | | | | | | | | | | | 2 x 28 máx. |
| 25 | | | | | 85339 | | | | | 85340 | | 85341 |
| 32 | 1/8" NPT | | 85345 | | | | | 85350 | | 85352 | 2 x 70 máx. | |

Anillo magnético estándar

Operación: 14 psi a 130 psi, cuerpo en aleación de aluminio, sellos en NBR

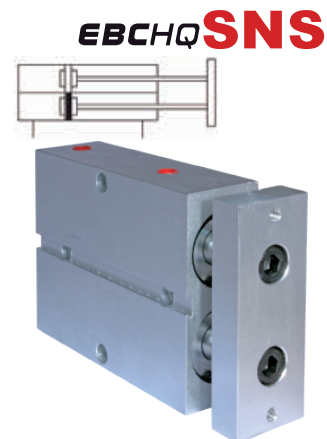
ACTUADORES NEUMÁTICOS CILINDROS COMPACTOS SERIE SDA, DOBLE EFECTO

| DIÁMETRO (mm) | PUERTOS | ROSCA DEL VÁSTAGO | CARRERA (mm) | | | | | | | | FUERZA TEÓRICA(Kg) | |
|---------------|----------|-------------------|--------------|-------|-------|-------|----|----|----|-----|--------------------|----------|
| | | | 15 | 20 | 25 | 50 | 70 | 80 | 90 | 100 | | |
| 12 | M5 | M3 x 0.5 | | | 87020 | 87022 | | | | | | 10 máx. |
| 16 | | | | | 87026 | 87028 | | | | | | 14 máx. |
| 20 | | | | | | 87031 | | | | | | |
| 25 | 1/8" NPT | M4 x 0.7 | | | | | | | | | | 44 máx. |
| 32 | | M5 x 0.8 | | | | | | | | | | 70 máx. |
| 40 | | M6 x 1.0 | 87034 | 87036 | 87038 | 87040 | | | | | | 110 máx. |
| 50 | 1/4" NPT | M8 x 1.25 | | | 87043 | 87045 | | | | | | 170 máx. |
| | | M10 x 1.50 | | | 87048 | 87050 | | | | | | |

Anillo magnético estándar

Operación: 14 psi a 130 psi, cuerpo en aleación de aluminio, sellos en NBR

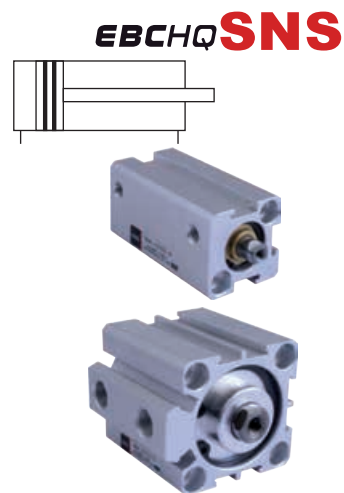
ACTUADORES NEUMÁTICOS MINI CILINDROS SERIE CJPB, SIMPLE EFECTO

| DIÁMETRO (mm) | PUERTOS | ROSCA DEL VÁSTAGO | CARRERA (mm) | | | | FUERZA TEÓRICA(Kg) |
|---------------|---------|-------------------|--------------|-------|----|-------|--------------------|
| | | | 5 | 10 | 15 | 20 | |
| 6 | M5 | M3 x 0.5 | | 87000 | | | 1.4 máx. |
| 10 | | M4 x 0.7 | | 87002 | | | 4 máx. |
| 15 | | M5 x 0.8 | | | | 87004 | 10 máx. |

Sin amortiguación regulable, sin anillo magnético

Operación: 14 psi a 100 psi, Cuerpo en Bronce con recubrimiento cromado, sellos en NBR





| REF | MODELO | EXTERIOR | CARRERA (mm) | MAX. ENERGIA DE ABSORCIÓN | | me MAX. MASA EFECTIVA (kg) | VELOCIDAD DE IMPACTO |
|-------|-----------|-----------|--------------|---------------------------|----------------------------|----------------------------|----------------------|
| | | | | W ₃ (N.m) | W ₄ (N.m/ hora) | | |
| 87490 | AD-1412-1 | M14 x 1.5 | 12 | 20 | 25,000 | 100 | 3 m/s (max.) |
| 87491 | AD-2020-1 | M20 x 1.5 | 20 | 60 | 40,000 | 250 | 3.5 m/s (max.) |
| 87492 | AD-2525-1 | M25 x 1.5 | 25 | 85 | 70,000 | 400 | |
| 87493 | AD-2550-1 | | 50 | 150 | 80,000 | 800 | |
| 87494 | AD-3650-1 | M36 x 1.5 | 50 | 300 | 100,000 | 700 | 3 m/s (max.) |

Cuerpo en aleacion de aluminio

Selección de amortiguadores

Para seleccionar el mejor amortiguador para su aplicación, proceda como se indica a continuación:

1- Determinar la aplicación: use los ejemplos.

2- Use la fórmula o elija ejemplos para calcular:

energía total por ciclo: **W₃**, (energía total por hora: **W₄**, peso efectivo: **me**

Estos valores le ayudarán a seleccionar el amortiguador que mejor se adapte a su aplicación.

3- Seleccione en la tabla (parte superior) la capacidad de los amortiguadores con valores superiores a **W₃**, **W₄** y **me**.

Para lograr el mejor resultado, seleccione amortiguadores que trabajen entre 50 y 80% de la energía máxima (**W₃**).

Verifique que el peso efectivo **me** esté entre los valores del amortiguador elegido.

4- Controle la carrera del amortiguador:

si coincide con la carrera de su aplicación, el amortiguador seleccionado le brindará buenos resultados.

Nota:

Si utiliza más de un amortiguador en la aplicación, divida **me**, **W₃** y **W₄** por la cantidad de amortiguadores.

Fórmulas y ejemplos de cálculo

Aproximadamente el 90% de las aplicaciones son fáciles de calcular conociendo solamente los 4 parámetros opuestos:

1. Masa a ralentizar **m** (kg)
2. Velocidad de impacto en el amortiguador **V_D** (m/s)
3. Fuerza de impulso **F** (N)
4. Ciclos por hora **C** (1/h)

SÍMBOLOS UTILIZADOS

| SÍMBOLO | DESCRIPCIÓN | UNIDAD | SÍMBOLO | DESCRIPCIÓN | UNIDAD |
|-----------------|---|--------|---------|---|------------------|
| W ₁ | Energía cinética por ciclo | Nm | HM | Factor de parada (Normal 2,5) | 1 a 3 |
| W ₂ | Energía de la fuerza impulsora x ciclo | Nm | M | Por impulso | Nm |
| W ₃ | Energía total por ciclo (W1 + W2) | Nm | J | Momento de inercia | kgm ² |
| W ₄ | Energía total por hora (W3. x) | Nm/h | g | Aceleración debida a la fuerza de gravedad=9,81 | m/s ² |
| me | Peso efectivo | kg | h | Pérdida de altura (Sin la carrera del amortiguador) | m |
| m | Masa a ralentizar | kg | s | Carrera del amortiguador | m |
| n | Cantidad de amortiguadores | | L/R/r | Radio | m |
| *V | Velocidad de las masas movidas | m/s | Q | Fuerza reactiva | N |
| *V _D | Velocidad de impacto en el amortiguador | m/s | μ | Coefficiente de fricción | |
| ω | Velocidad angular | 1/s | t | Tiempo de desaceleración | s |
| f | Fuerza de impulso | N | a | Desaceleración | m/s ² |
| X | Ciclos por hora | /hr | ∞ | Ángulo de la carga lateral | ° |
| P | Potencia del motor | kW | β | Ángulo de inclinación | ° |

*V y *V_D es la velocidad final de impacto de la masa. Con movimiento de aceleración la velocidad final puede llegar a ser 1,5 a 2 veces superior a la medida.

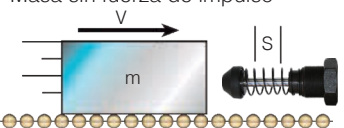
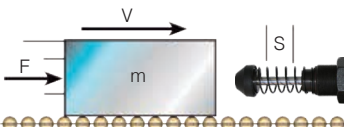
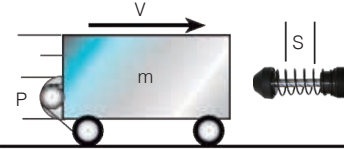
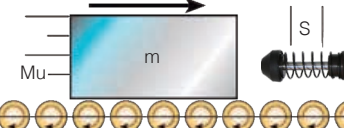
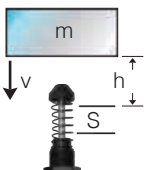
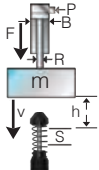
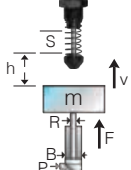
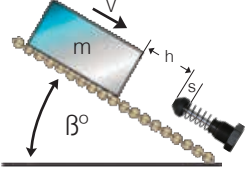
| APLICACIÓN | FORMULA | EJEMPLO | CÁLCULO Y SELECCIÓN |
|---|---|---|--|
| 1 - Masa sin fuerza de impulso  | $W_1 = m \cdot v^2 \cdot 0,5$ $W_2 = 0$ $W_3 = W_1 + W_2$ $W_4 = W_3 \cdot x$ $V_D = v$ $me = m$ | $m = 10 \text{ kg}$ $v = 1,5 \text{ m/s}$ $x = 500 \text{ /hr}$ $s = 0,012 \text{ m (elegido)}$ | $W_1 = 10 \cdot 1,5^2 \cdot 0,5 = 11,25 \text{ Nm}$ $W_2 = 0$ $W_3 = 11,25 + 0 = 11,25 \text{ Nm}$ $W_4 = 11,25 \cdot 500 = 5\,625 \text{ Nm/h}$ $me = m = 10 \text{ kg}$ Elegido según el diagrama de capacidad: Modelo 87490 |
| 2 - Masa con fuerza de impulso  | $W_1 = m \cdot v^2 \cdot 0,5$ $W_2 = F \cdot s$ $W_3 = W_1 + W_2$ $W_4 = W_3 \cdot x$ $V_D = v$ $me = 2 \cdot W_3 / V_D^2$ | $m = 36 \text{ kg}$ $*v = 1,5 \text{ m/s}$ $F = 200 \text{ N}$ $x = 1000 \text{ /hr}$ $s = 0,025 \text{ m (elegido)}$ | $W_1 = 36 \cdot 1,5^2 \cdot 0,5 = 41 \text{ Nm}$ $W_2 = 200 \cdot 0,025 = 5 \text{ Nm}$ $W_3 = 41 + 5 = 46 \text{ Nm}$ $W_4 = 46 \cdot 1000 = 46\,000 \text{ Nm/h}$ $me = 2 \cdot 51 / 1,5^2 = 45 \text{ kg}$ Elegido según el diagrama de capacidad: Modelo 87492 *v es la velocidad de impacto final de la masa. En sistemas con impulsión neumática, puede llegar a ser 1,5 a 2 veces más alta que la velocidad promedio. Al calcular la energía, téngalo en cuenta. |
| 3 - Masa con propulsión motorizada  | $W_1 = m \cdot v^2 \cdot 0,5$ $W_2 = F \cdot s$ $W_3 = W_1 + W_2$ $W_4 = W_3 \cdot x$ $V_D = v$ $me = 2 \cdot W_3 / V_D^2$ | $m = 100 \text{ kg}$ $v = 1,2 \text{ m/s}$ $HM = 2,5$ $P = 2 \text{ kW}$ $x = 100 \text{ /hr}$ $s = 0,05 \text{ m (elegido)}$ | $W_1 = 100 \cdot 1,2^2 \cdot 0,5 = 72 \text{ Nm}$ $W_2 = 1000 \cdot 2 \cdot 2,5 \cdot 0,05 / 1,2 = 209 \text{ Nm}$ $W_3 = 72 + 209 = 281 \text{ Nm}$ $W_4 = 281 \cdot 100 = 28\,100 \text{ Nm/h}$ $me = 2 \cdot 281 / 1,2^2 = 390 \text{ kg}$ Seleccionado según el diagrama de capacidad: 2 unidades del modelo 87493 No olvidar incluir en el cálculo la energía de rotación del motor, acople o caja de engranajes W1. |
| 4 - Masa en los rodillos propulsores  | $W_1 = m \cdot v^2 \cdot 0,5$ $W_2 = m \cdot \mu \cdot g \cdot s$ $W_3 = W_1 + W_2$ $W_4 = W_3 \cdot x$ $V_D = v$ $me = 2 \cdot W_3 / V_D^2$ | $m = 250 \text{ kg}$ $v = 1,5 \text{ m/s}$ $x = 180 \text{ /hr}$ $\mu = 0,2 \text{ (acero/acero)}$ $s = 0,05 \text{ m (elegido)}$ | $W_1 = 250 \cdot 1,5^2 \cdot 0,5 = 281 \text{ Nm}$ $W_2 = 250 \cdot 0,2 \cdot 9,81 \cdot 0,05 = 25 \text{ Nm}$ $W_3 = 281 + 25 = 306 \text{ Nm}$ $W_4 = 306 \cdot 180 = 55\,080 \text{ Nm/h}$ $me = 2 \cdot 306 / 1,5^2 = 272 \text{ kg}$ Seleccionado según el diagrama de capacidad: 2 unidades del modelo 87494 |
| 5 - Masa en caída libre  | $W_1 = m \cdot g \cdot h$ $W_2 = m \cdot g \cdot s$ $W_3 = W_1 + W_2$ $W_4 = W_3 \cdot x$ $V_D = \dot{O}(2 \cdot g \cdot h)$ $me = 2 \cdot W_3 / V_D^2$ | $m = 30 \text{ kg}$ $h = 0,5 \text{ m}$ $x = 400 \text{ /hr}$ $s = 0,05 \text{ m (elegido)}$ | $W_1 = 30 \cdot 0,5 \cdot 9,81 = 147 \text{ Nm}$ $W_2 = 30 \cdot 9,81 \cdot 0,05 = 15 \text{ Nm}$ $W_3 = 147 + 15 = 162 \text{ Nm}$ $W_4 = 162 \cdot 400 = 64\,800 \text{ Nm/h}$ $V_D = \dot{O}(2 \cdot 9,81 \cdot 0,5) = 3,13 \text{ m/s}$ $me = 2 \cdot 162 / 3,13^2 = 33 \text{ kg}$ Seleccionado según el diagrama de capacidad: Modelo 87494 |
| 6 - Limitador inferior de Cilindro  | $W_1 = m \cdot v^2 \cdot 0,5$ $W_2 = (m \cdot g + F) \cdot s$ $W_3 = W_1 + W_2$ $W_4 = W_3 \cdot x$ $V_D = \dot{O}(2 \cdot g \cdot h)$ $me = 2 \cdot W_3 / V_D^2$ | $m = 30 \text{ kg}$ $h = 0,5 \text{ m}$ $v = 1,0 \text{ m/s}$ $F = 200 \text{ N}$ $x = 400 \text{ /hr}$ $s = 0,05 \text{ m (elegido)}$ | $W_1 = 30 \cdot 1,0^2 \cdot 9,81 = 294 \text{ Nm}$ $W_2 = (30 \cdot 9,81 + 200) \cdot 0,05 = 25 \text{ Nm}$ $W_3 = 294 + 15 = 309 \text{ Nm}$ $W_4 = 309 \cdot 400 = 123\,600 \text{ Nm/h}$ $V_D = \dot{O}(2 \cdot 9,81 \cdot 0,5) = 3,13 \text{ m/s}$ $me = 2 \cdot 309 / 3,13^2 = 64 \text{ kg}$ Seleccionado según el diagrama de capacidad: 2 unidades del modelo 87494 |
| 7 - Limit. superior de Cilindro  | $W_1 = m \cdot v^2 \cdot 0,5$ $W_2 = (m \cdot g - F) \cdot s$ $W_3 = W_1 + W_2$ $W_4 = W_3 \cdot x$ $V_D = \dot{O}(2 \cdot g \cdot h)$ $me = 2 \cdot W_3 / V_D^2$ | $m = 30 \text{ kg}$ $h = 0,5 \text{ m}$ $v = 1,0 \text{ m/s}$ $F = 200 \text{ N}$ $x = 400 \text{ /hr}$ $s = 0,05 \text{ m (elegido)}$ | $W_1 = 30 \cdot 1,0^2 \cdot 9,81 = 294 \text{ Nm}$ $W_2 = (30 \cdot 9,81 - 200) \cdot 0,05 = 5 \text{ Nm}$ $W_3 = 294 + 5 = 299 \text{ Nm}$ $W_4 = 299 \cdot 400 = 119\,600 \text{ Nm/h}$ $V_D = \dot{O}(2 \cdot 9,81 \cdot 0,05) = 3,13 \text{ m/s}$ $me = 2 \cdot 299 / 3,13^2 = 61 \text{ kg}$ Seleccionado según el diagrama de capacidad: 2 unidades del modelo 87494 |
| 8 - Caída libre - inclinada  | $W_1 = m \cdot g \cdot h = m \cdot VD^2 \cdot 0,5$ $W_2 = m \cdot g \cdot \sin\beta \cdot s$ $W_3 = W_1 + W_2$ $W_4 = W_3 \cdot x$ $V_D = \dot{O}(2 \cdot g \cdot h)$ $me = 2 \cdot W_3 / V_D^2$ | 8.1 fuerza de impulso inclinada hacia arriba $W_2 = (F - m \cdot g \cdot \sin\beta) \cdot s$ 8.2 fuerza de impulso inclinada hacia abajo $W_2 = (F + m \cdot g \cdot \sin\beta) \cdot s$ | |

Fuerza reactiva Q (N)

$$Q = \frac{1,5 \cdot W_3}{S}$$

Tiempo de parada (s)

$$t = \frac{2,6 \cdot s}{V_D}$$

Desaceleración (m/s²)

$$Q = \frac{0,75 \cdot V_D^2}{S}$$

Valores aproximados con ajustes correctos. Agregar márgenes de seguridad si es necesario.



| REF. | MODELO | VOLTAJE RANGO DE OPERACIÓN | MAX. CAPACIDAD DE CONTACTO | TIEMPO DE RESPUESTA | RESISTENCIA AL IMPACTO | TEMP. AMBIENTE °C | GRADO DE PROTECCIÓN | INDICADOR | LONG. DEL CABLE (mt) | VIDA ÚTIL OPERACIONES |
|-------|--------|----------------------------|----------------------------|---------------------|---------------------------|-------------------|---------------------|------------|----------------------|-----------------------|
| 85150 | CS1-U | 5~240V AC/DC | 10W | 1ms | 300m/s ² (30G) | 0 ~ 60 | IP67 | LED (Rojo) | 2 | 5 Millones |
| 85330 | CS1-G | | | 0.3ms | | | | | | |
| 85362 | CS1-J | | | 5~120V AC/DC | | -10 ~ 70 | | | | |
| 85393 | CS1-M | | | | | | | | | |
| 85331 | D-A93 | | | | | | | | | |
| 85390 | D-A73L | | | | | | | | | |
| 85391 | D-Z73 | | | | | | | | | |

| REF. | MODELO | FOTO | DIMENSIONES |
|-------|--------|------|-------------|
| 85150 | CS1-U | | |
| 85330 | CS1-G | | |
| 85362 | CS1-J | | |
| 85393 | CS1-M | | |
| 85331 | D-A93 | | |
| 85390 | D-A73L | | |
| 85391 | D-Z73 | | |

**FACTORES DE CONVERSIÓN DE LAS UNIDADES DE MEDIDA DE PRESIÓN
(VALORES ABSOLUTOS)**

| | = mbar | = bar | = torr | = inch. Hg | = psi (lbf/in ²) | = atm | = Kg/cm ² (at) | = mm H ₂ O | = m H ₂ O | = Pa (N/m ²) |
|----------------------------|---------------------------|-------------------------|-------------------------|-------------------------|---------------------------------|--------------------------|------------------------------|-----------------------|--------------------------|-----------------------------|
| mbar | x 1 | 10 ⁻³ | 0,75 | 2,95x 10 ⁻² | 14,5 x 10 ⁻³ | 9,87 x 10 ⁻⁴ | 1,02 x 10 ⁻³ | 10,2 | 1,02 x 10 ⁻² | 100,0 |
| bar | x 1000,0 | 1 | 750,0 | 29,53 | 14,6 | 0,987 | 1,02 | 10197,0 | 10,19 | 100000 |
| torr | x 1,33 | 1,33 x 10 ⁻³ | 1 | 3,94 x 10 ⁻² | 1,93 x 10 ⁻² | 1,316 x 10 ⁻³ | 1,359 x 10 ⁻³ | 13,59 | 1,359 x 10 ⁻³ | 133,32 |
| inch. Hg | x 33,9 | 33,9 x 10 ⁻³ | 25,4 | 1 | 0,491 | 3,34 x 10 ⁻² | 3,45 x 10 ⁻² | 345,0 | 0,345 | 3386,0 |
| psi (lbf/in ²) | x 68,9 | 6,89 x 10 ⁻² | 51,7 | 2,04 | 1 | 6,8 x 10 ⁻² | 7,03 x 10 ⁻² | 703 | 0,703 | 6897 |
| atm | x 1013,25 | 1,013 | 760,0 | 30,0 | 14,696 | 1 | 1,033 | 10332 | 10,332 | 101325,0 |
| Kg/cm ² (at) | x 981 | 0,981 | 735,6 | 28,96 | 14,2 | 0,968 | 1 | 10000 | 10 | 98067,0 |
| mm H ₂ O | x 9,81 x 10 ⁻² | 9,81 x 10 ⁻⁵ | 7,35 x 10 ⁻² | 2,89 x 10 ⁻³ | 1,42 x 10 ⁻³ | 9,67 x 10 ⁻⁵ | 10 ⁻⁴ | 1 | 10 ⁻³ | 9,8067 |
| m H ₂ O | x 98,067 | 9,81 x 10 ⁻² | 73,5 | 2,89 | 1,42 | 9,67 x 10 ⁻² | 10 | 10000 | 1 | 9806,7 |
| Pa (N/m ²) | x 0,01 | 10 ⁻⁵ | 7,5 x 10 ⁻³ | 2,95 x 10 ⁻⁴ | 1,45 x 10 ⁻⁴ | 9,87 x 10 ⁻⁶ | 1,02 x 10 ⁻⁵ | 0,102 | 1,02 x 10 ⁻⁴ | 1 |

Ejemplo: para convertir 10 mbar en Torr = 10 x 0,75 = 7,5 Torr

Unidades de Fuerza

| Newton | Kgf | lbf | toneladas métricas |
|--------|-------|-------|--------------------|
| 1 | 0.102 | 0.224 | 0.000102 |
| 9.81 | 1 | 2.204 | 0.001 |
| 4.44 | 0.453 | 1 | 0.00045 |
| 9807 | 1000 | 2205 | 1 |

$$1N=1 \frac{kg \times m}{seg^2}$$

Unidades de Volumen

| m ³ | litro | pie ³ | galón |
|----------------|-------|------------------|-------|
| 1 | 1000 | 35,31 | 264,2 |
| 0,001 | 1 | 0,035 | 0,26 |
| 0,02832 | 28,32 | 1 | 7,48 |
| 0,0037 | 3,78 | 0,133 | 1 |

Unidades de Flujo

| l/min | m ³ /h | pie ³ /min | galón/min |
|---------|-------------------|-----------------------|-----------|
| 1 | 0,06 | 0,035 | 0,264 |
| 0,001 | 1 | 0,589 | 4,402 |
| 0,02832 | 1,69 | 1 | 7,48 |
| 0,0037 | 0,227 | 0,133 | 1 |

Estamos a la disposición de nuestros clientes para ofrecer soluciones en el área textil, farmacéutica, alimentacia, manufactura, papel y cartón, envasado, industria del plástico, área de bombas de agua, avícola.

Nos dedicamos a la distribución de equipo eléctrico industrial como también, brindamos servicios de programación de PLC, Migración de variadores entre marcas. Pantallas HMI, Controles de temperatura y procesos, Variadores de velocidad, servodrives y servomotores, sistemas SCADA, Diseño de diagramas eléctricos, electrónicos y neumáticos Revisión y diagnóstico para maquinaria.

www.sautec.net

MÁTICA



ACCESORIOS MANGUERAS

PISTOLAS PARA AIRE

EBCHQ

| REF | REF. DE FABRICA | PUERTO | BOQUILLA (S) | MATERIAL | COLOR |
|--------|-----------------|----------|---------------------------|----------|-------|
| 85997* | 989 | 1/4" NPT | 1 de 16 mm | Metálico | Metal |
| 85999* | DG-10 | | 2 unidades de 16 y 100 mm | | |
| 86001 | AR-TS | | 1 de 100 mm | Plástico | Rojo |

Presión de Trabajo máx. 130psi (9.14 kg/cm²), para aire o agua, temperatura de operación 70°C máx.
 *Con conector acople rápido

| REF | REF. DE FABRICA | DIÁMETRO CORTE | USOS | MATERIAL | COLOR |
|--------------|-----------------|----------------|--|----------|-------|
| NUEVO | QA-8 | 4 a 8 mm | Corte preciso de mangueras plasticas de PU o nylon | Plástico | Azul |
| 85993 | QA-10 | 8 a 12 mm | | | |
| 85995 | TK-1 | 4 a 13 mm | | Metálico | Negro |



85995

85993

Nuevo

MATERIAL ALEACIÓN DE ZINC

| <p>Conector macho - Rosca hembra</p> <p>PF</p> <table border="1"> <thead> <tr> <th>REF.</th> <th>MODELO</th> <th>HP</th> <th>C</th> <th>LP</th> <th>T</th> </tr> </thead> <tbody> <tr> <td>85726</td> <td>PF - 10</td> <td rowspan="2">17H</td> <td rowspan="2">20</td> <td rowspan="2">36</td> <td>1/8"NPT</td> </tr> <tr> <td>85727</td> <td>PF - 20</td> <td>1/4"NPT</td> </tr> <tr> <td>85728</td> <td>PF - 30</td> <td>19H</td> <td></td> <td></td> <td>3/8"NPT</td> </tr> </tbody> </table> | REF. | MODELO | HP | C | LP | T | 85726 | PF - 10 | 17H | 20 | 36 | 1/8"NPT | 85727 | PF - 20 | 1/4"NPT | 85728 | PF - 30 | 19H | | | 3/8"NPT | <p>Conector macho - Rosca macho</p> <p>PM</p> <table border="1"> <thead> <tr> <th>REF.</th> <th>MODELO</th> <th>A</th> <th>HP</th> <th>LP</th> <th>T</th> </tr> </thead> <tbody> <tr> <td>85731</td> <td>PM - 10</td> <td>13.8</td> <td>14H</td> <td>40.8</td> <td>1/8"NPT</td> </tr> <tr> <td>85732</td> <td>PM - 20</td> <td>13.8</td> <td>14H</td> <td>40.8</td> <td>1/4"NPT</td> </tr> <tr> <td>85733</td> <td>PM - 30</td> <td>14.2</td> <td>17H</td> <td>41.2</td> <td>3/8"NPT</td> </tr> </tbody> </table> | REF. | MODELO | A | HP | LP | T | 85731 | PM - 10 | 13.8 | 14H | 40.8 | 1/8"NPT | 85732 | PM - 20 | 13.8 | 14H | 40.8 | 1/4"NPT | 85733 | PM - 30 | 14.2 | 17H | 41.2 | 3/8"NPT | | | | | | | | | |
|--|---------|-------------|-------------|--------------|---------|------|--------------|--------------|--------------|--------------|-------|---------|---|---------|--------------|--------------|--------------|--------------|---------|--------------|---------|--|------|--------|---|------|---------|---|--------------|---------|------|-----|------|--------------|--------------|---------|--------------|---------|------|---------|--------------|--------------|---------|---------|--------------|--------------|---------|--------------|---------|----|---|--|--|------|---------|
| REF. | MODELO | HP | C | LP | T | | | | | | | | | | | | | | | | | | | | | | | | | | | | | | | | | | | | | | | | | | | | | | | | | | |
| 85726 | PF - 10 | 17H | 20 | 36 | 1/8"NPT | | | | | | | | | | | | | | | | | | | | | | | | | | | | | | | | | | | | | | | | | | | | | | | | | | |
| 85727 | PF - 20 | | | | 1/4"NPT | | | | | | | | | | | | | | | | | | | | | | | | | | | | | | | | | | | | | | | | | | | | | | | | | | |
| 85728 | PF - 30 | 19H | | | 3/8"NPT | | | | | | | | | | | | | | | | | | | | | | | | | | | | | | | | | | | | | | | | | | | | | | | | | | |
| REF. | MODELO | A | HP | LP | T | | | | | | | | | | | | | | | | | | | | | | | | | | | | | | | | | | | | | | | | | | | | | | | | | | |
| 85731 | PM - 10 | 13.8 | 14H | 40.8 | 1/8"NPT | | | | | | | | | | | | | | | | | | | | | | | | | | | | | | | | | | | | | | | | | | | | | | | | | | |
| 85732 | PM - 20 | 13.8 | 14H | 40.8 | 1/4"NPT | | | | | | | | | | | | | | | | | | | | | | | | | | | | | | | | | | | | | | | | | | | | | | | | | | |
| 85733 | PM - 30 | 14.2 | 17H | 41.2 | 3/8"NPT | | | | | | | | | | | | | | | | | | | | | | | | | | | | | | | | | | | | | | | | | | | | | | | | | | |
| <p>Conector hembra - Rosca hembra</p> <p>SF</p> <table border="1"> <thead> <tr> <th>REF.</th> <th>MODELO</th> <th>A</th> <th>BS</th> <th>D</th> <th>HS</th> <th>LS</th> <th>T</th> </tr> </thead> <tbody> <tr> <td>85736</td> <td>SF - 10</td> <td rowspan="2">9.4</td> <td rowspan="2">6</td> <td rowspan="2">26</td> <td rowspan="2">19H</td> <td rowspan="2">50.2</td> <td>1/8"NPT</td> </tr> <tr> <td>85737</td> <td>SF - 20</td> <td>1/4"NPT</td> </tr> <tr> <td>85738</td> <td>SF - 30</td> <td>15</td> <td>8</td> <td></td> <td></td> <td>55.8</td> <td>3/8"NPT</td> </tr> </tbody> </table> | REF. | MODELO | A | BS | D | HS | LS | T | 85736 | SF - 10 | 9.4 | 6 | 26 | 19H | 50.2 | 1/8"NPT | 85737 | SF - 20 | 1/4"NPT | 85738 | SF - 30 | 15 | 8 | | | 55.8 | 3/8"NPT | <p>Conector hembra - Rosca macho</p> <p>SM</p> <table border="1"> <thead> <tr> <th>REF.</th> <th>MODELO</th> <th>A</th> <th>BS</th> <th>D</th> <th>HS</th> <th>LS</th> <th>T</th> </tr> </thead> <tbody> <tr> <td>85741</td> <td>SM - 10</td> <td rowspan="2">9.7</td> <td rowspan="2">6</td> <td rowspan="2">26</td> <td rowspan="2">19H</td> <td rowspan="2">50.2</td> <td>1/8"NPT</td> </tr> <tr> <td>85742</td> <td>SM - 20</td> <td>1/4"NPT</td> </tr> <tr> <td>85743</td> <td>SM - 30</td> <td>15</td> <td>8</td> <td></td> <td></td> <td>55.8</td> <td>3/8"NPT</td> </tr> </tbody> </table> | REF. | MODELO | A | BS | D | HS | LS | T | 85741 | SM - 10 | 9.7 | 6 | 26 | 19H | 50.2 | 1/8"NPT | 85742 | SM - 20 | 1/4"NPT | 85743 | SM - 30 | 15 | 8 | | | 55.8 | 3/8"NPT |
| REF. | MODELO | A | BS | D | HS | LS | T | | | | | | | | | | | | | | | | | | | | | | | | | | | | | | | | | | | | | | | | | | | | | | | | |
| 85736 | SF - 10 | 9.4 | 6 | 26 | 19H | 50.2 | 1/8"NPT | | | | | | | | | | | | | | | | | | | | | | | | | | | | | | | | | | | | | | | | | | | | | | | | |
| 85737 | SF - 20 | | | | | | 1/4"NPT | | | | | | | | | | | | | | | | | | | | | | | | | | | | | | | | | | | | | | | | | | | | | | | | |
| 85738 | SF - 30 | 15 | 8 | | | 55.8 | 3/8"NPT | | | | | | | | | | | | | | | | | | | | | | | | | | | | | | | | | | | | | | | | | | | | | | | | |
| REF. | MODELO | A | BS | D | HS | LS | T | | | | | | | | | | | | | | | | | | | | | | | | | | | | | | | | | | | | | | | | | | | | | | | | |
| 85741 | SM - 10 | 9.7 | 6 | 26 | 19H | 50.2 | 1/8"NPT | | | | | | | | | | | | | | | | | | | | | | | | | | | | | | | | | | | | | | | | | | | | | | | | |
| 85742 | SM - 20 | | | | | | 1/4"NPT | | | | | | | | | | | | | | | | | | | | | | | | | | | | | | | | | | | | | | | | | | | | | | | | |
| 85743 | SM - 30 | 15 | 8 | | | 55.8 | 3/8"NPT | | | | | | | | | | | | | | | | | | | | | | | | | | | | | | | | | | | | | | | | | | | | | | | | |
| <p>Conector para manguera macho</p> <p>PH</p> <table border="1"> <thead> <tr> <th>REF.</th> <th>MODELO</th> <th>Adapt.</th> <th>A</th> <th>B</th> <th>D</th> <th>E</th> </tr> </thead> <tbody> <tr> <td>85745</td> <td>PH - 10</td> <td>1/4" I.D.</td> <td rowspan="2">52.8</td> <td rowspan="2">24</td> <td rowspan="2">4.9</td> <td rowspan="2">9</td> </tr> <tr> <td>85746</td> <td>PH - 20</td> <td>5/16" I.D.</td> </tr> <tr> <td>85747</td> <td>PH - 30</td> <td>3/8" I.D.</td> <td>52.5</td> <td></td> <td>7.2</td> <td>9.8</td> </tr> </tbody> </table> | REF. | MODELO | Adapt. | A | B | D | E | 85745 | PH - 10 | 1/4" I.D. | 52.8 | 24 | 4.9 | 9 | 85746 | PH - 20 | 5/16" I.D. | 85747 | PH - 30 | 3/8" I.D. | 52.5 | | 7.2 | 9.8 | <p>Conector para manguera hembra</p> <p>SH</p> <table border="1"> <thead> <tr> <th>REF.</th> <th>MODELO</th> <th>A</th> <th>Con.</th> <th>D</th> <th>HS</th> <th>LS</th> <th>T</th> </tr> </thead> <tbody> <tr> <td>85750</td> <td>SH - 10</td> <td rowspan="3">26</td> <td>1/8"</td> <td rowspan="3">26</td> <td rowspan="3">19H</td> <td rowspan="3">66.8</td> <td>7</td> </tr> <tr> <td>85751</td> <td>SH - 20</td> <td>1/4"</td> <td>9</td> </tr> <tr> <td>85752</td> <td>SH - 30</td> <td>3/8"</td> <td>11</td> </tr> </tbody> </table> | REF. | MODELO | A | Con. | D | HS | LS | T | 85750 | SH - 10 | 26 | 1/8" | 26 | 19H | 66.8 | 7 | 85751 | SH - 20 | 1/4" | 9 | 85752 | SH - 30 | 3/8" | 11 | | | | | | |
| REF. | MODELO | Adapt. | A | B | D | E | | | | | | | | | | | | | | | | | | | | | | | | | | | | | | | | | | | | | | | | | | | | | | | | | |
| 85745 | PH - 10 | 1/4" I.D. | 52.8 | 24 | 4.9 | 9 | | | | | | | | | | | | | | | | | | | | | | | | | | | | | | | | | | | | | | | | | | | | | | | | | |
| 85746 | PH - 20 | 5/16" I.D. | | | | | | | | | | | | | | | | | | | | | | | | | | | | | | | | | | | | | | | | | | | | | | | | | | | | | |
| 85747 | PH - 30 | 3/8" I.D. | 52.5 | | 7.2 | 9.8 | | | | | | | | | | | | | | | | | | | | | | | | | | | | | | | | | | | | | | | | | | | | | | | | | |
| REF. | MODELO | A | Con. | D | HS | LS | T | | | | | | | | | | | | | | | | | | | | | | | | | | | | | | | | | | | | | | | | | | | | | | | | |
| 85750 | SH - 10 | 26 | 1/8" | 26 | 19H | 66.8 | 7 | | | | | | | | | | | | | | | | | | | | | | | | | | | | | | | | | | | | | | | | | | | | | | | | |
| 85751 | SH - 20 | | 1/4" | | | | 9 | | | | | | | | | | | | | | | | | | | | | | | | | | | | | | | | | | | | | | | | | | | | | | | | |
| 85752 | SH - 30 | | 3/8" | | | | 11 | | | | | | | | | | | | | | | | | | | | | | | | | | | | | | | | | | | | | | | | | | | | | | | | |
| <p>Conexión 1/4"NPT (Hembra)</p> <table border="1"> <thead> <tr> <th>REF.</th> <th>MODELO</th> <th>No. PUERTOS</th> </tr> </thead> <tbody> <tr> <td>85715</td> <td>SML 2</td> <td>2</td> </tr> <tr> <td>85716</td> <td>SML 3</td> <td>3</td> </tr> <tr> <td>85717</td> <td>SML 4</td> <td>4</td> </tr> </tbody> </table> | REF. | MODELO | No. PUERTOS | 85715 | SML 2 | 2 | 85716 | SML 3 | 3 | 85717 | SML 4 | 4 | <p>Conexión 1/4"NPT (Hembra)</p> <table border="1"> <thead> <tr> <th>REF.</th> <th>MODELO</th> <th>No. PUERTOS</th> </tr> </thead> <tbody> <tr> <td>85720</td> <td>SMV 2</td> <td>2</td> </tr> <tr> <td>85722</td> <td>SMY 3</td> <td>3</td> </tr> </tbody> </table> | REF. | MODELO | No. PUERTOS | 85720 | SMV 2 | 2 | 85722 | SMY 3 | 3 | | | | | | | | | | | | | | | | | | | | | | | | | | | | | | | | | |
| REF. | MODELO | No. PUERTOS | | | | | | | | | | | | | | | | | | | | | | | | | | | | | | | | | | | | | | | | | | | | | | | | | | | | | |
| 85715 | SML 2 | 2 | | | | | | | | | | | | | | | | | | | | | | | | | | | | | | | | | | | | | | | | | | | | | | | | | | | | | |
| 85716 | SML 3 | 3 | | | | | | | | | | | | | | | | | | | | | | | | | | | | | | | | | | | | | | | | | | | | | | | | | | | | | |
| 85717 | SML 4 | 4 | | | | | | | | | | | | | | | | | | | | | | | | | | | | | | | | | | | | | | | | | | | | | | | | | | | | | |
| REF. | MODELO | No. PUERTOS | | | | | | | | | | | | | | | | | | | | | | | | | | | | | | | | | | | | | | | | | | | | | | | | | | | | | |
| 85720 | SMV 2 | 2 | | | | | | | | | | | | | | | | | | | | | | | | | | | | | | | | | | | | | | | | | | | | | | | | | | | | | |
| 85722 | SMY 3 | 3 | | | | | | | | | | | | | | | | | | | | | | | | | | | | | | | | | | | | | | | | | | | | | | | | | | | | | |



| REF | REF. DE FABRICA | DIMENSIONES APROXIMADAS EN mm | | | | | |
|-------|-----------------|-------------------------------|-------------------------|-------------------------|---|----------|----------|
| | | Rosca | Diámetro D ₁ | Diámetro D ₂ | Uso con | Hexagono | Longitud |
| 86100 | BG06-01 | G1/8" | 3 | 4,5 | Manguera de D _{int} 4mm / 5mm o 0.179" | 10 | 25,2 |
| 86101 | BG06-02 | G1/4" | | | | 14 | 26,5 |
| 86102 | BG06-03 | G3/8" | | | | 17 | 27,5 |
| 86103 | BG06-04 | G1/2" | | | | 21 | 28,5 |
| 86106 | BG08-01 | G1/8" | 4 | 6 | Manguera de D _{int} 5mm / 6mm o 1/4" | 10 | 26,0 |
| 86107 | BG08-02 | G1/4" | | | | 14 | 26,5 |
| 86108 | BG08-03 | G3/8" | | | | 17 | 28,0 |
| 86109 | BG08-04 | G1/2" | | | | 21 | 28,5 |
| 86112 | BG10-01 | G1/8" | 5 | 7,5 | Manguera de D _{int} 8mm o 5/16" | 10 | 30,0 |
| 86113 | BG10-02 | G1/4" | | | | 14 | |
| 86114 | BG10-03 | G3/8" | | | | 17 | |
| 86115 | BG10-04 | G1/2" | | | | 21 | |
| 86118 | BG12-01 | G1/8" | 6,5 | 9,5 | Manguera de D _{int} 10mm o 3/8" | 11 | 28,5 |
| 86119 | BG12-02 | G1/4" | | | | 14 | 31,0 |
| 86120 | BG12-03 | G3/8" | | | | 17 | |
| 86121 | BG12-04 | G1/2" | | | | 21 | |

Material: Bronce (Se recomienda después de la conexión colocar abrazadera)

Generalidades técnicas

Tipos de roscas

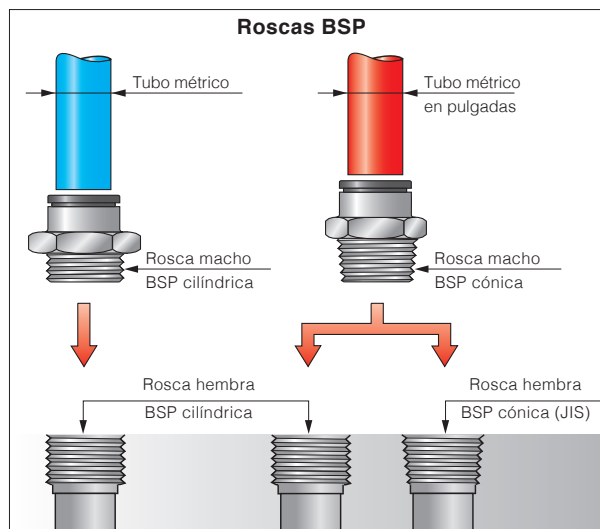

Roscas BSP (British Standard Pipe)

Estas roscas con perfil "Gas" pueden ser de dos tipos :

Cilíndricas : se montan en el mismo roscado cilíndrico. La estanqueidad queda asegurada por una junta tórica incorporada (o por una arandela).

• cónicas : se montan en el mismo roscado cilíndrico o cónico. La estanqueidad queda asegurada por un precoating en la rosca.

Descripción de las roscas

• BSP cilíndrica : G seguido de la descripción, según norma ISO 228-1

Ejemplo : rosca 1/8 BSP cilíndrica ÜG1/8

• BSP cónica : R seguido de la descripción, según norma ISO 7-1

Ejemplo : rosca 1/8 BSP cónica ÜR1/8

• roscas hembras :

BSP cilíndrica : G seguido de la descripción

BSP cónica : Rc seguido de la descripción

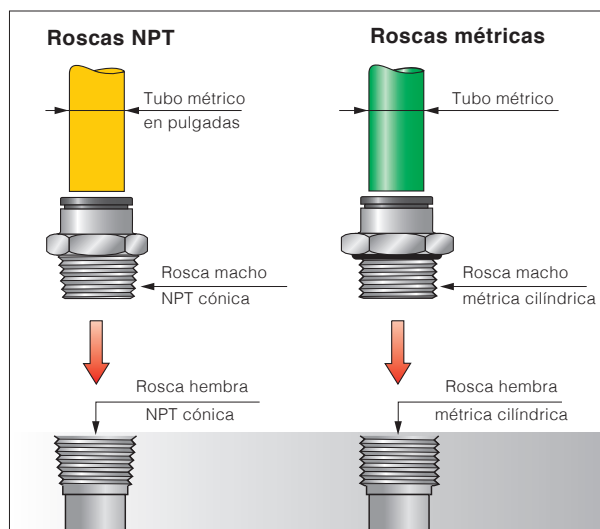

Roscas métricas

Estas roscas con perfil ISO son del tipo cilíndrico.

Se montan en el mismo roscado cilíndrico. La estanqueidad queda asegurada por una junta tórica incorporada (o por una arandela).

Descripción de las roscas

• M seguido de los valores del diámetro y del paso en milímetros, separados por el signo de multiplicar, según norma ISO 68-1 e ISO 965-1

Ejemplo : M7x1.

Roscas NPT (National Pipe Thread)

Se refiere a un estándar americano, de tipo cónico. se montan en el mismo roscado cónico. La estanqueidad queda asegurada por un precoating en la rosca.